

Applications manual

For tankless and point-of-use water heaters



BOSCH

Invented for life

Table of Contents

<u>1 Introduction</u>	4
<u>2 Bosch Water Heating Model Certifications</u>	4
<u>3 Bosch Water Heater Accessories</u>	5
<u>4 Water Quality</u>	5
<u>5 Pump Sizing</u>	6
5.1 Pressure drop curves	6
5.2 Domestic hot water circulation	7
5.3 Tank loading	7
<u>6 Bosch Water Heating Models & Specifications</u>	8
6.1 Sizing tankless water heaters	8
6.2 Outdoor Installation	10
6.3 Bosch gas tankless water heater specifications	11
6.4 Bosch electric tankless water heater specifications	12
2.5 Ariston electric mini-tank water heater specifications	12
<u>7 Domestic Water Heating Applications</u>	13
7.1 Point-of-use applications	13
7.2 Whole house applications	16
<u>8 High Volume Potable Water Heating</u>	22
8.1 Cascading unit applications	23
8.2 Parallel unit applications	25
<u>9 Residential Solar Applications</u>	26
9.1 Tankloading	26
9.2 Booster applications	27
<u>10 Commercial Solar Applications</u>	29
<u>11 Commercial Water Heating Applications</u>	30
11.1 Commercial kitchen applications	30
11.2 Basic tank loading with domestic recirculation	32
11.3 Advanced tank loading commercial hot water system	33

1 Introduction

The Bosch Applications Manual is intended to present some of the most common applications of the Bosch line of tankless and point of use water heaters. Application drawings are shown with both piping and corresponding electrical schematics where applicable. Auxiliary equipment depicted does not necessarily represent any one manufacturer or specific model number. There are a wide variety of techniques, practices and piping strategies possible when installing water heating appliances. It is the responsibility of the installing contractor to determine the most suitable arrangement for the application.

i All drawings are conceptual in nature and does not address all design, installation or safety considerations. Additional safety and/or auxiliary equipment may be needed. Drawings are for reference use by officials, designers and licensed installers. It is expected that installers have adequate knowledge of accepted industry practices for the equipment, procedures, and applications involved. It is the responsibility of the installer to ensure that the installation is in accordance with local building codes.

Although this manual covers many common applications for our products, system possibilities are virtually endless. Should you encounter an application that is not covered in this manual or have any questions regarding any of its content, we encourage you to contact your local sales representative or us directly at Bosch Thermotechnology .

This manual is not a substitute for any of the product's installation manuals. All specifications subject to change.

i Installation must conform with local codes or, in the absence of local codes, the National Fuel Gas Code ANSI Z223.1/NFPA 54.
In Canada: Installation must conform with CGA B149.(1,2) INSTALLATION CODES and/or local installation codes.

2 Bosch Water Heating Model Certifications

The following are certification stamps and explanations that are specific to one or more Bosch tankless water heaters. These certifications bring the appliances in accordance with the requirements of the National Fuel Gas Code ANSI Z223.1/NFPA 54.



Certified to applicable U.S. standards for appliances using gas or other petroleum fuel.



Certified to applicable Canadian standards for appliances using gas or other petroleum fuel.



Certified by Underwriters Laboratories Inc.



Energy efficiency certified by Gas Appliance Manufacturers Association (GAMA), www.gamanet.org



For Models GWH C 920 ES, GWH C 920 ESC only
These models are built in accordance with the requirements of the ASME Boiler and Pressure Vessel Code and received the Certificate of Authorization from the National Board. The heat exchanger has the NB and the HLW stamps.



Plumbing-Heating-Cooling Contractors Association

Other certifications:

- ▶ Met the California Energy Commission (CEC) standards
- ▶ Approved by the Commonwealth of Massachusetts
- ▶ South Coast Air Quality Management

3 Tankless Water Heater accessories

See Table 1 for available accessories for the Bosch line of tankless water heaters.

NOTE: Only models that have accessories available are listed in the table below.

Available accessories	Table 1		
	715 ES	C 800 ES	C 920 ES/ESC
Concentric Vent/air Intake kit - stainless steel (part# ESHCK)	√		
Concentric termination kit - PVC (part# 196016)		√	√
Exhaust / intake bird screen (part# L2594)		√	√
Vertical vent kit (part# ESVVT)	√		
Horizontal vent kit (part# 4TWHVK3SII)	√		
Outdoor kit (part# PTOK)	√	√	√
Wireless remote control (part# TSTAT2)	√	√	√
Cascading kit (part# TLINK)	√	√	√
Freeze prevention kit (part# 7709003665)	√	√	√
External water filter (part# 8703305356)	√	√	√
Gas conversion kit (part# 8719002176)	√		
PVC Condensate drain tee (part# 196061)*		√	√
Condensate neutralization cartridge kit (part# JM-2KIT)		√	√

* Also included in the Concentric termination kit (part# 196016)

4 Water Quality

Poor water quality will have an impact on appliance longevity and may void the manufacturer's warranty. For water analysis data call your local water department, or if on a well, have well water analyzed periodically. If water quality exceeds one or more of the values specified below, Bosch recommends consulting a local water treatment professional for water softening/conditioning options.

Water quality max. levels	Table 2	
	Max. Levels	
pH	pH	6.5 - 8.5
TDS (Total Dissolved Solids)	mg/l or ppm	500
Total hardness	mg/l or ppm	100 (6 grains)
Aluminum	mg/l or ppm	2.0
Chlorides	mg/l or ppm	250
Copper	mg/l or ppm	1.0
Iron	mg/l or ppm	0.3
Manganese	mg/l or ppm	0.05
Zinc	mg/l or ppm	5.0

5 Pump sizing

The following section outlines sizing pumps for domestic hot water circulation and tank loading. Only models approved for such applications are listed in this section.

- ▶ Pump must be bronze or stainless steel.
- ▶ Size the pump according to the system pressure drop chart below.
- ▶ Maximum flow allowed through the recirc loop is 5 GPM.

i If the water heater is used within an approved hot water recirculation application and supplied with circulated water, the heat exchanger warranty is decreased. Please refer to the installation manual for detailed warranty period information.

i Run the system for 30 minutes to remove debris from the plumbing. Then remove the unit's inlet water filter to decrease pressure drop through the system. If the inlet water filter, when removed, contains debris install a Y-strainer (installer supplied) on the cold water inlet.

5.1 Pressure drop curves

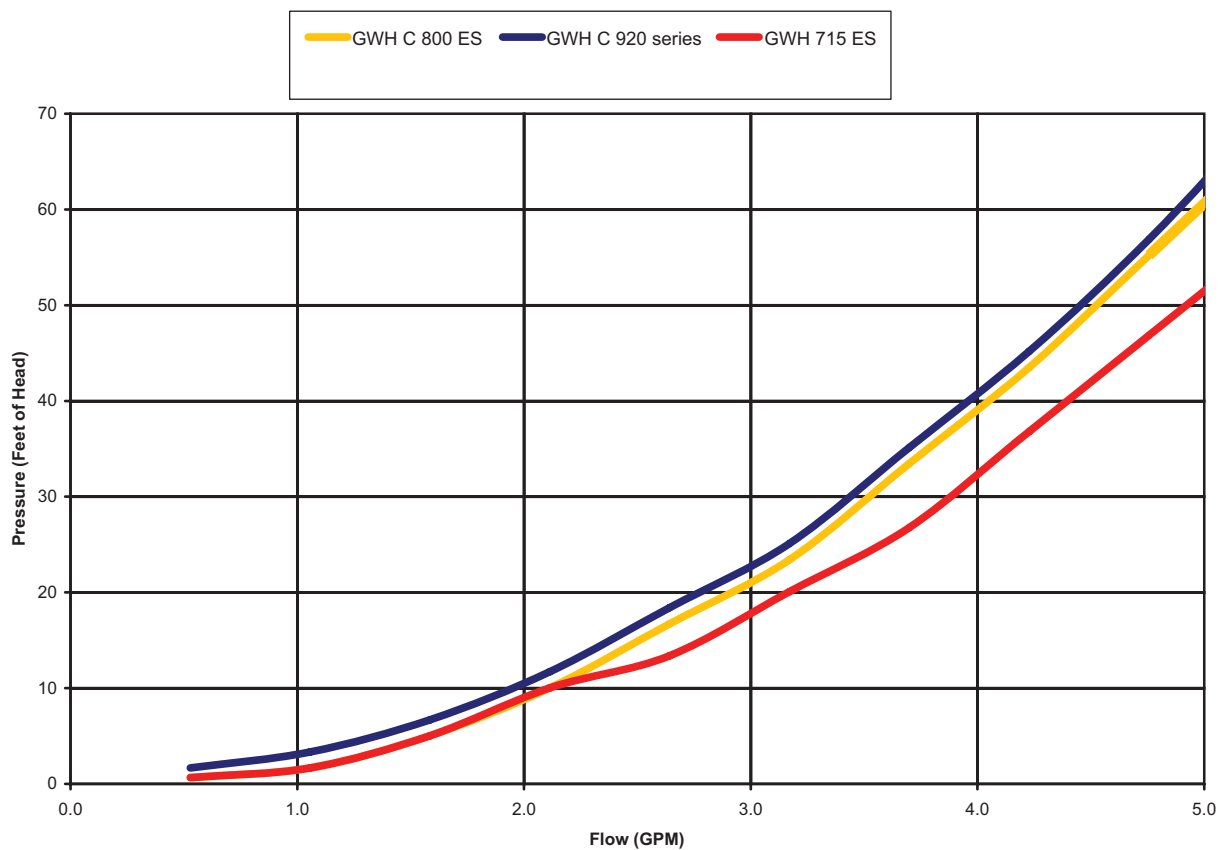

5.2 Domestic hot water circulation

► **Must provide a recirculation flow above 1.7 GPM.** This can be verified in the control unit diagnostics section of the installation manual; mode P4 – 3d.

► **Note:** The Grundfos model 15-55 has been tested and shown to work on recirculating systems up to 120 feet of total pipe length. System conditions vary and each pump must be sized by a professional to insure performance.

Refer to pump manufacturers flow vs pressure specifications to select a pump that can provide the flow rate greater than 1.7 gpm while overcoming the pressure loss through:

- Tankless water heater (see Chapter 6.1)
- All building supply and return plumbing in the circulation loop (reference local plumbing codes, standards, or practices)

System pressure drop	
	Pressure drop ¾" copper (PSI)
90 degree elbow	0.088
45 degree elbow	0.053
10 ft of straight pipe ½"	1.3
10 ft of straight pipe ¾"	0.35

Source: International Plumbing Code 2003 edition.

Examples:

1) Average house (less than 2500 square feet)

- Total loop length approximately 120 ft
- Pump recommendation: Grundfos UP 15-55 or equivalent.

2) Large house (2500 to 5000 square feet)

- Total loop length approximately 240 ft
- Pump recommendation: Grundfos UP 25-64 or equivalent.

NOTE: Use only bronze or stainless steel pumps. Do not use pumps of iron construction as they will oxidize and clog the inlet filter on the appliance.

Recommendations for domestic hot water recirculation

- An Aquastat, with a 5° F differential to control the pump, is recommended.
- The usage of a timer is recommended to limit the energy consumption. The timer should also limit recirculation pump operation to the time of day when occupants are home and likely to use hot water.
- Water heater set point must be minimum of 14° F above the Aquastat setpoint.
Example: Tankless water heater setpoint = 122°F
Aquastat setpoint = 108°F
- Keep hot water piping insulated to limit heat loss.
- Set temperature on the GWH 920 ESC must not exceed 140°F.

5.3 Tank loading

Table 2		
# of heaters	Pressure drop vs. flow Models: C800ES, C920ES, C920ESC	Pressure drop vs. flow Model: 715ES
1	4gpm @ 40 feet of head	4gpm @ 32 feet of head
2	8gpm @ 40 feet of head	8gpm @ 32 feet of head
3	12gpm @ 40 feet of head	12gpm @ 32 feet of head
4	16gpm @ 40 feet of head	16gpm @ 32 feet of head

These guidelines should be followed to maximize system output:

- Ensure flow through each water heater is between 3.5-5.0 gpm
- Isolation valves or boiler drains should be installed to facilitate descaling in applications with hard water.
- Whenever possible, plumb the system or configure the tank to draw cold supply water into the water heater during hot water use.

We recommend Grundfos UP26-99, Taco 009 or equivalent potable water circulators.

6 Bosch Water Heating Models and Specifications

This section describes the water heaters available from Bosch Thermotechnology Corporation and provides a general overview to the specifications of that particular model. More detailed information is contained in the installation manuals. Download these manuals at www.BoschPro.com.

6.1 Sizing tankless water heaters

Definitions

- ▶ Major applications (2 GPM or more): Washing machine, bath tub, shower nozzle
- ▶ Minor applications (2 GPM or less): Low flow shower head, bathroom sink, kitchen sink

Rule of thumb sizing

The tables below provide a general rule of thumb when sizing for most residential applications. For commercial applications or for a more detailed sizing method, use the **Sizing by Chart** instructions below in conjunction with the charts on the next page.

Rule of Thumb Sizing		
Model Number	Number of Major Applications	Number of Minor Applications
GWH C 920 ES/ESC	3	1
GWH 715 ES	2	0
GWH C 800 ES	2	1
GWH 425 HN/PN	1	1
GWH 425 HN/PN	0	2
GWH 260 PN	1	0
RP17PT	1	0
RP27PT	1	1

Sizing by Chart

- ▶ Measure the flow rates at each fixture that will be used simultaneously and add them together. If only one application will be used at a time measure each fixture and use the maximum flow rate observed
- ▶ Using a known volume container, record several fill times. Perform the calculation below to determine the flow rate (a one gallon fill time of 30 seconds is 2.0 gallons per minute (GPM)):

$$\text{Flow rate (GPM)} = \frac{\text{Volume (gallons)}}{\text{Fill time (sec)}} \times 60 \frac{\text{sec}}{\text{min}}$$

- ▶ Using a thermometer, measure the incoming water temperature. For reference, see average ground water temperature map. Subtract this temperature from the desired hot water temperature to get the degree rise. If the desired hot water temperature is 120F and incoming temperature is 55F, the desired degree rise is 65F.

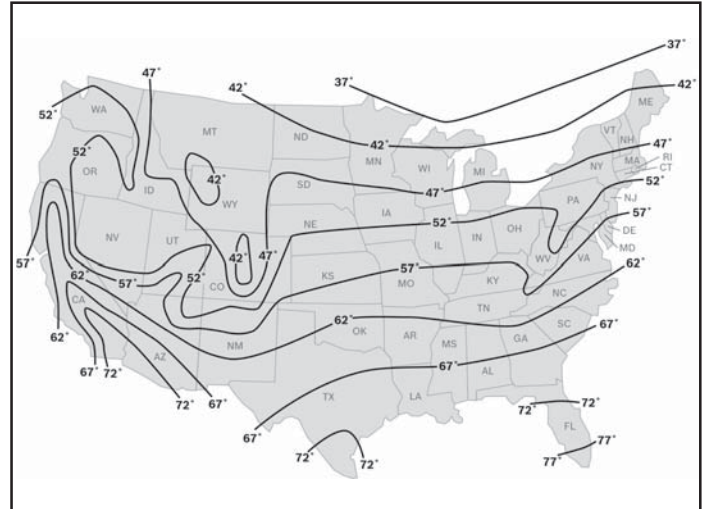
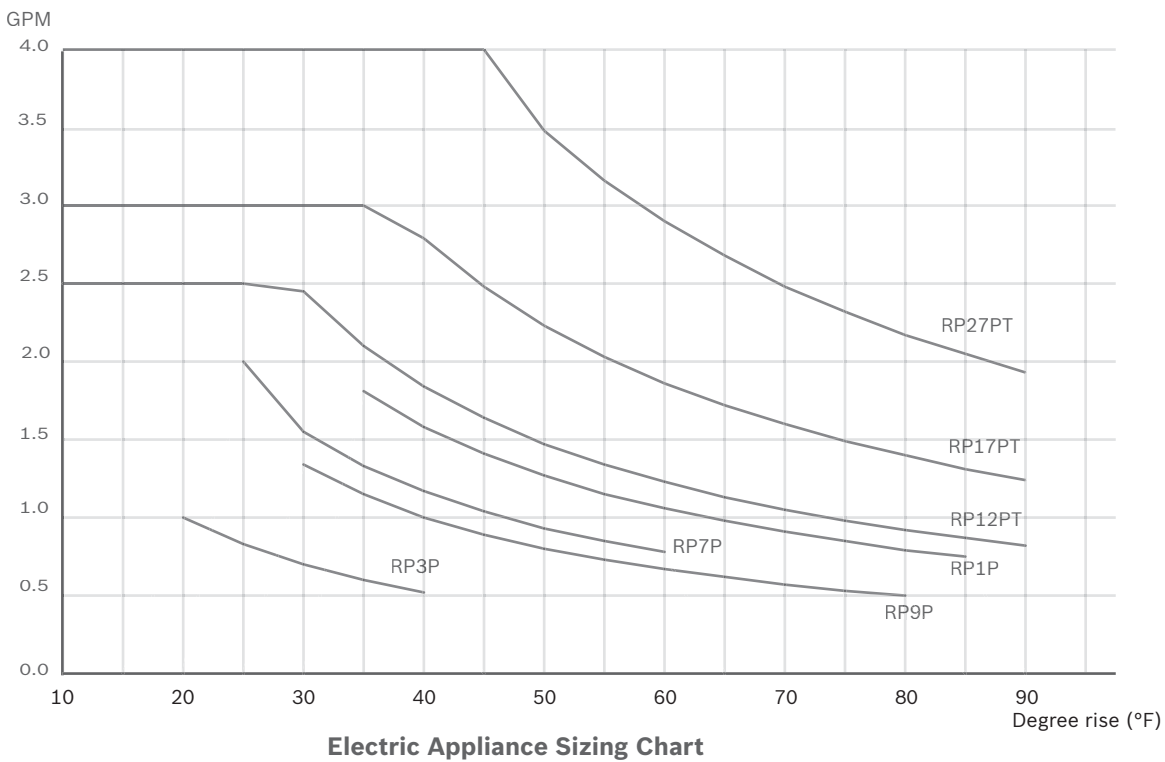
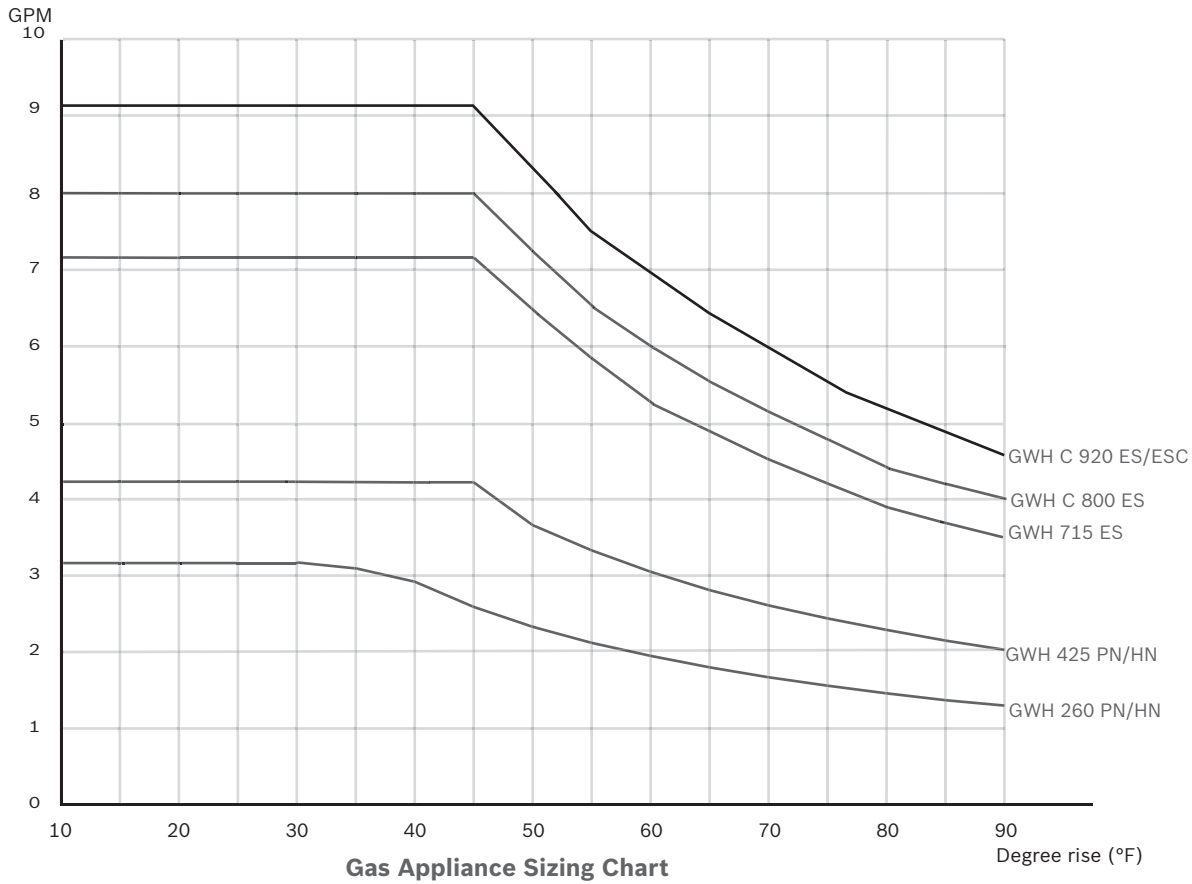

Figure 1 Average ground water temperatures

- ▶ This example requires a flow rate of 2.0 GPM at a 65°F rise. Refer to the graphs on the following page. Since the demand is above the GWH 260 PN capacity, this application would require a GWH 425 HN/PN gas tankless water heater. The electrical model used for this application would be the RP27PT electric tankless water heater.



Note: Maximum flow rates dependent on site conditions

6.2 Outdoor Installation

All models listed in this manual are designed to be installed indoors. However, the following models are approved for outdoor installation with the use of the Outdoor Kit (part# PTOK):

- ▶ GWH 715 ES
- ▶ GWH C 800 ES
- ▶ GWH C 920 ES
- ▶ GWH C 920 ESC

Outdoor Kit (PTOK) installation:

- ▶ The installation of this outdoor kit (PTOK) is required when installing any of the above appliances outdoors.
- ▶ Outdoor cap easily retrofits to these indoor models.
- ▶ Outdoor kit comes with Freeze Prevention which must be installed.
- ▶ Exterior water piping should be protected if short term freezing conditions could exist.
- ▶ Not for use in areas routinely exposed to freezing temperatures.

Minimum clearances:

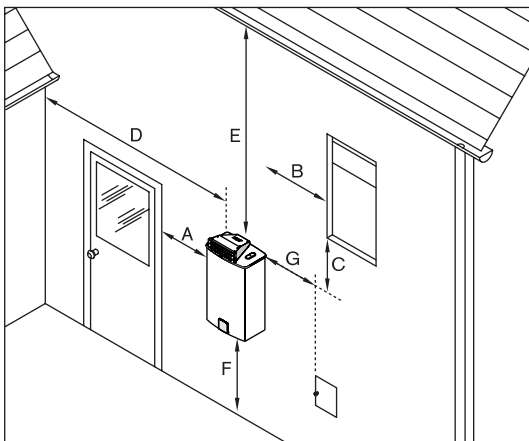

Ref.	Description	Min. distances
A	Directly below or adjacent to an opening; operable windows, doors and any fresh air openings	≥ 1 ft
B		
C		
D	From any adjacent wall	≥ 4 ft
E	Below a gutter, sanitary pipework, eaves or overhang	≥ 3 ft
F	Above ground	≥ 1 ft
G	From a gas meter or gas regulator	≥ 5 ft

Outdoor Installation Clearances

Source: NFPA 54 National Fuel Gas Code
ANSI Z223.1

Installation on wood siding

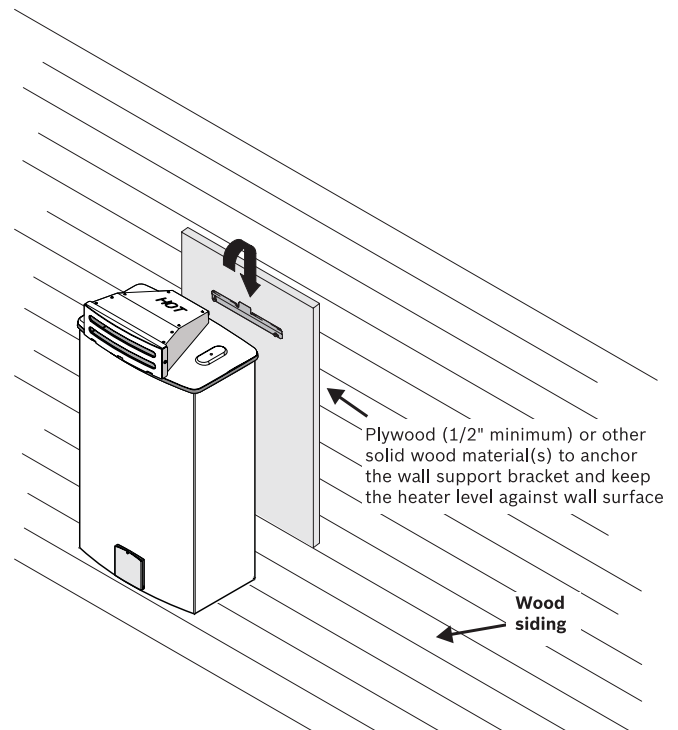

Installation on vinyl siding:

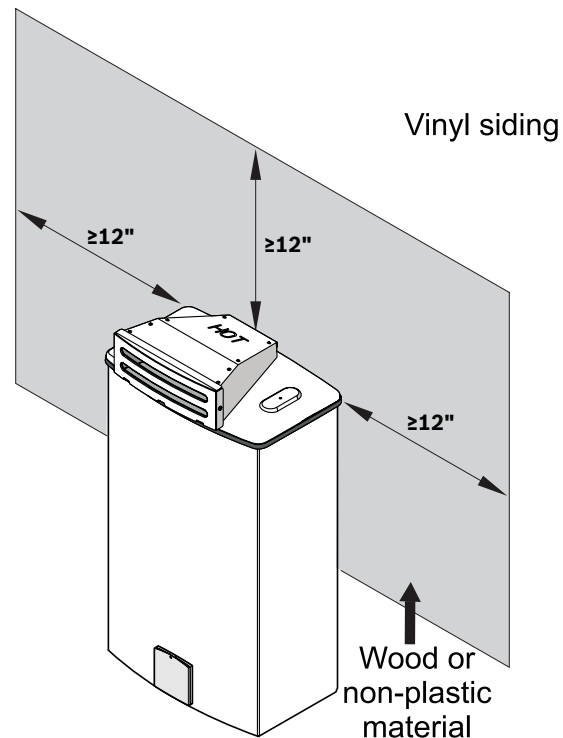

6.3 Bosch Gas Tankless Water Heater Specifications

Technical Specifications						
Model	260 PN	425 PN	425 HN	715 ES	C 800 ES	C 920 ES/ESC
Gas input (BTU/hr)	Min: 30,735	Min: 31,000	Min: 30,735	Min: 19,900	Min: 19,900	Min: 25,000
	Max: 74,900	Max: 117,000	Max: 117,000	Max: 199,000	Max: 199,000	Max: 225,000
Minimum flow to activate (GPM)	0.6	0.6	0.6	0.65	0.65	0.65
Maximum flow rate at 45° rise (GPM)	2.6	4.2	4.2	7.2	8.0	9.2
Maximum flow rate at 90° rise (GPM)	1.3	2.1	2.1	3.6	3.9	4.6
Thermal Efficiency	NG: 78% LP: 78%	NG: 78% LP: 78%	NG: 80% LP: 80%	NG: 82% LP: 82%	NG: 92% LP: 92%	NG: 94% LP: 94%
Dimensions (inches)	H: 28¾ W: 12¼ D: 8½	H: 25¾ W: 16¾ D: 8½	H: 25¾ W: 16¾ D: 8½	H: 30½ W: 17⅞ D: 11¼	H: 30½ W: 17⅞ D: 11¼	H: 30½ W: 17⅞ D: 11¼
Weight (lbs.)	25	33	33	67	74	88
Modulating gas valve	yes	yes	yes	yes	yes	yes
Ignition	Standing pilot	Standing pilot	Hydro-generated	Electronic	Electronic	Electronic
Gas connection	½" Male NPT	¾" Male NPT	¾" Male NPT	¾" Male NPT	¾" Male NPT	¾" Male NPT
Water connections	½" Male NPT	¾" Male NPT	¾" Male NPT	¾" Male NPT	¾" Male NPT	¾" Male NPT
NG gas pressure (inches of W.C.)	Min: 7 Max: 14	Min: 7 Max: 14	Min: 7 Max: 14	Min: 3.5 Max: 10.5	Min: 3.5 Max: 10.5	Min: 3.5 Max: 10.5
LP gas pressure (inches of W.C.)	Min: 11 Max: 14	Min: 11 Max: 14	Min: 11 Max: 14	Min: 8 Max: 13	Min: 8 Max: 13	Min: 8 Max: 13
Water pressure Static - (PSI)	Min: 30 Min (well): 40 Max: 150	Min: 30 Min (well): 40 Max: 150	Min: 30 Min (well): 40 Max: 150	Min: 30 Min (well): 40 Max: 150	Min: 30 Min (well): 40 Max: 150	Min: 30 Min (well): 40 Max: 150
Electrical supply	N/A	N/A	N/A	120VAC	120VAC	120VAC
Venting options	Vertical natural draft * horizontal termination not allowed	Vertical natural draft * horizontal termination only with AQ4 vent kit	Vertical natural draft * horizontal termination only with AQ4 vent kit	direct vent room-sealed combustion	direct vent room-sealed combustion	direct vent room-sealed combustion
Venting diameter (inches)	4	5	5	3 or 4	3 or 4	3 or 4
Vent material	Type B-vent recommended	Type B-vent recommended	Type B-vent recommended	Stainless steel (AL29-4C)	PVC, CPVC, or ABS (Schedule 40)	PVC, CPVC, or ABS (Schedule 40)

Note:

C 920 ES (residential model) has a maximum setpoint temperature of 140°F.

C 920 ESC (commercial model) has a maximum setpoint temperature of 180°F.

Note:

For specifications and details on the Bosch GWH 345 ESR and GWH 450 ESR models, see the GWH 345 ESR and GWH 450 ESR applications manual.

6.4 Bosch Electric Tankless Water Heater Specifications

Technical Specifications									
Model	RP1P	RP2P	RP3P	RP7P	RP9P	RP12PT	RP17PT	RP27PT	
Volts	240	277	120	240	277	240	240	240	
Kilowatts	9.50	6.00	3.40	7.20	9.50	12.00	17.25	26.85	
Amps	40	22	29	30	35	50	U.S.A.: 80 (2 x 40)	U.S.A.: 120 (3 x 40)	
							Canada: 80 (1 x 80)	Canada: 120 (1 x 120)	
Minimum wire size (AWG)	8	10	10	10	8	6	U.S.A.: 8	U.S.A.: 8	
							Canada: see Canadian Electrical Code	Canada: see Canadian Electrical Code	
Phase	Single	Single	Single	Single	Single	Single	Single	Single	
Minimum flow to activate (GPM)	0.75	0.50	0.50	0.75	0.75	0.75	0.6	0.8	
Maximum flow rate at 45° rise (GPM)	1.4	0.9	0.5	1.1	1.4	2.0	2.6	4.0	
Maximum flow rate at 80° rise (GPM)	n/a	0.5	n/a	n/a	n/a	n/a	1.5	2.2	
Thermal Efficiency	99%	99%	99%	99%	99%	99%	90%	94%	
Dimensions (inches)	H: 6½ W: 12¼ D: 3	H: 6½ W: 12¼ D: 3	H: 6½ W: 12¼ D: 3	H: 6½ W: 12¼ D: 3	H: 6½ W: 12¼ D: 3	H: 6½ W: 12¼ D: 3	H: 15½ W: 15¼ D: 4½	H: 15½ W: 15¼ D: 4½	
Weight (lbs.)	6	6	6	6	6	6	20	22	
Water connections	½" Male NPT	½" Male NPT	½" Male NPT	½" Male NPT	½" Male NPT	½" Male NPT	¾" Male NPT	¾" Male NPT	

6.5 Ariston Electric Mini-tank Water Heater Specifications

Technical Specifications			
Model	GL2.5Ti	GL4Ti	GL8Ti
Volts	120	120	120
Watts	1500	1500	1500
Amps	12.5	12.5	12.5
Wire size	Plug-in	Plug-in	Plug-in
Tank volume (gallons)	2.75	3.85	7.00
Dimensions (inches)	H: 14 W: 14 D: 10¼	H: 14 W: 14 D: 12¼	H: 17½ W: 17½ D: 14½
Recovery at 90° F rise (gallons per hour)	6.8	6.8	6.8
Temperature range	65 - 145° F	65 - 145° F	65 - 145° F
Water connections	½" Male NPT	½" Male NPT	¾" Male NPT
Operating pressure (PSI)	150	150	150

7 Domestic Water Heating Applications

Potable water

Potable water is water that is suitable for drinking. Bosch Water Heating appliances are approved to heat potable water only. Heating any other liquid other than potable water will void the manufacturer's warranty covering the appliance.

Introduction

This chapter covers the various application techniques Bosch Water Heating recommends. The schematics are to be used by professional contractors in designing a domestic water heating system. The applications covered range from single sink point-of-use applications to multi-appliance central domestic recirculation applications.

7.1 Point-of-use applications

Point-of-use applications cover the small applications in which a large water heater would be inefficient. Installing a smaller heater at a point-of-use puts the heater near the hot water demand and reduces the wait for hot water. Common applications for these appliances include homes, offices, warehouses, service stations, stores, concession stands and summer camps.

7.1.1 Ariston mini tank

Simply tap into the cold water line and install the water heater directly at the sink. All models plug into a standard 120 volt outlet. Heater can be wall mounted, or sit on the floor.

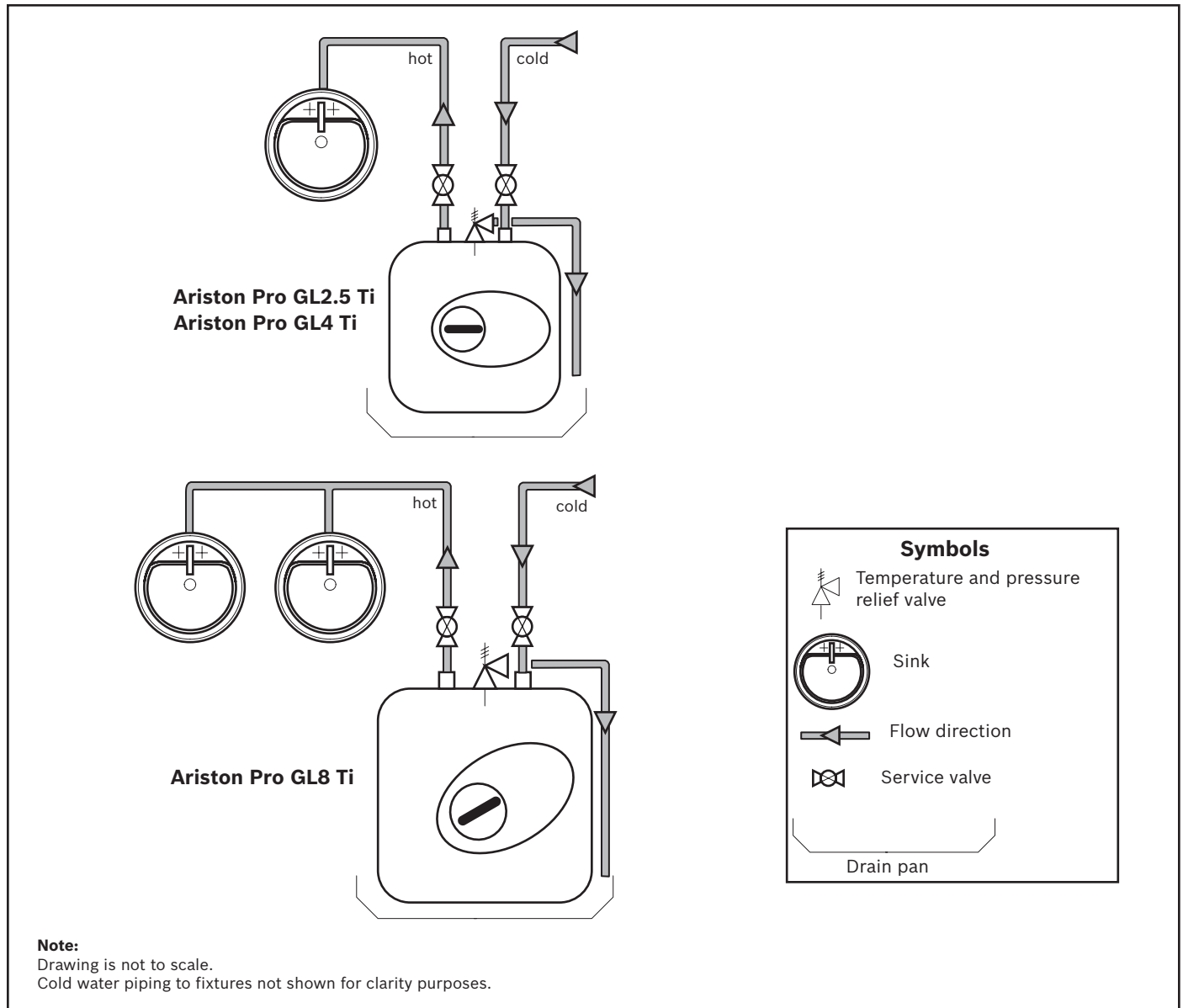

7.1.2 Powerstream Pro electric point-of-use tankless water heater

PowerstreamPro point-of-use water heaters come in four models to serve a wide range of applications. Finding the right model depends upon your desired temperature and flow rate. See Section 2.1 to find the model best suited to your customer's needs. Flow controls and faucet aerators can greatly enhance performance.

Note: Water heater must be filled with water and purged of air prior to supplying power.

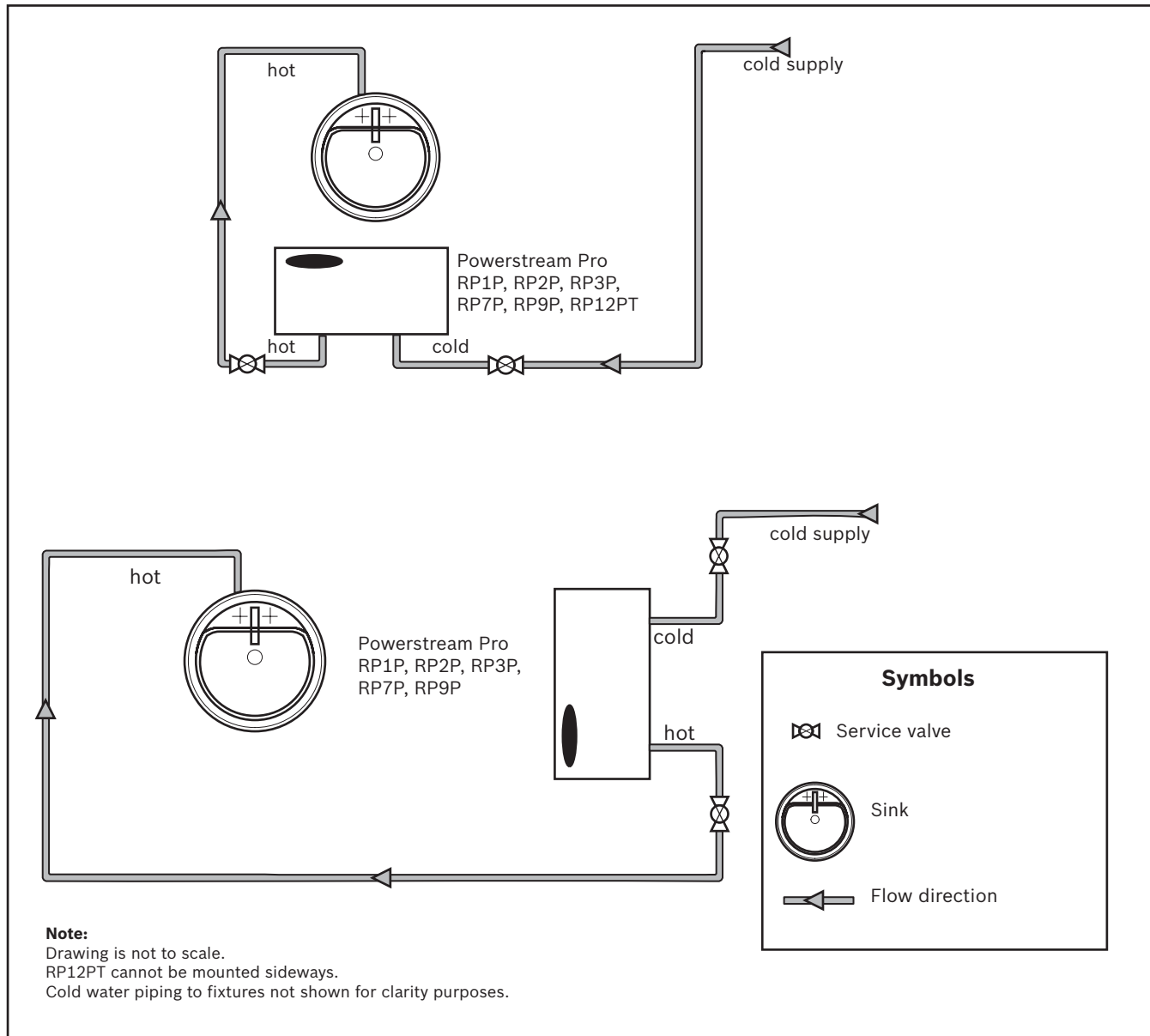

7.2 Whole house applications

Whole house applications cover the typical home applications up to a 2 or 3 bedroom house. See the sizing guide (Section 6.1) to determine the best Bosch water heater model for your application. An enhanced design including an Ariston mini tank in line to the hot water source will reduce the wait time for hot water and improve temperature stability.

7.2.1 Low volume tankless water heater applications

The Bosch GWH 260 PN gas tankless water heater and the RP17PT electric tankless water heater offer a compact and lightweight design for easy installation.

Both appliances are intended for low volume applications (e.g. camps, cottages, cabins).

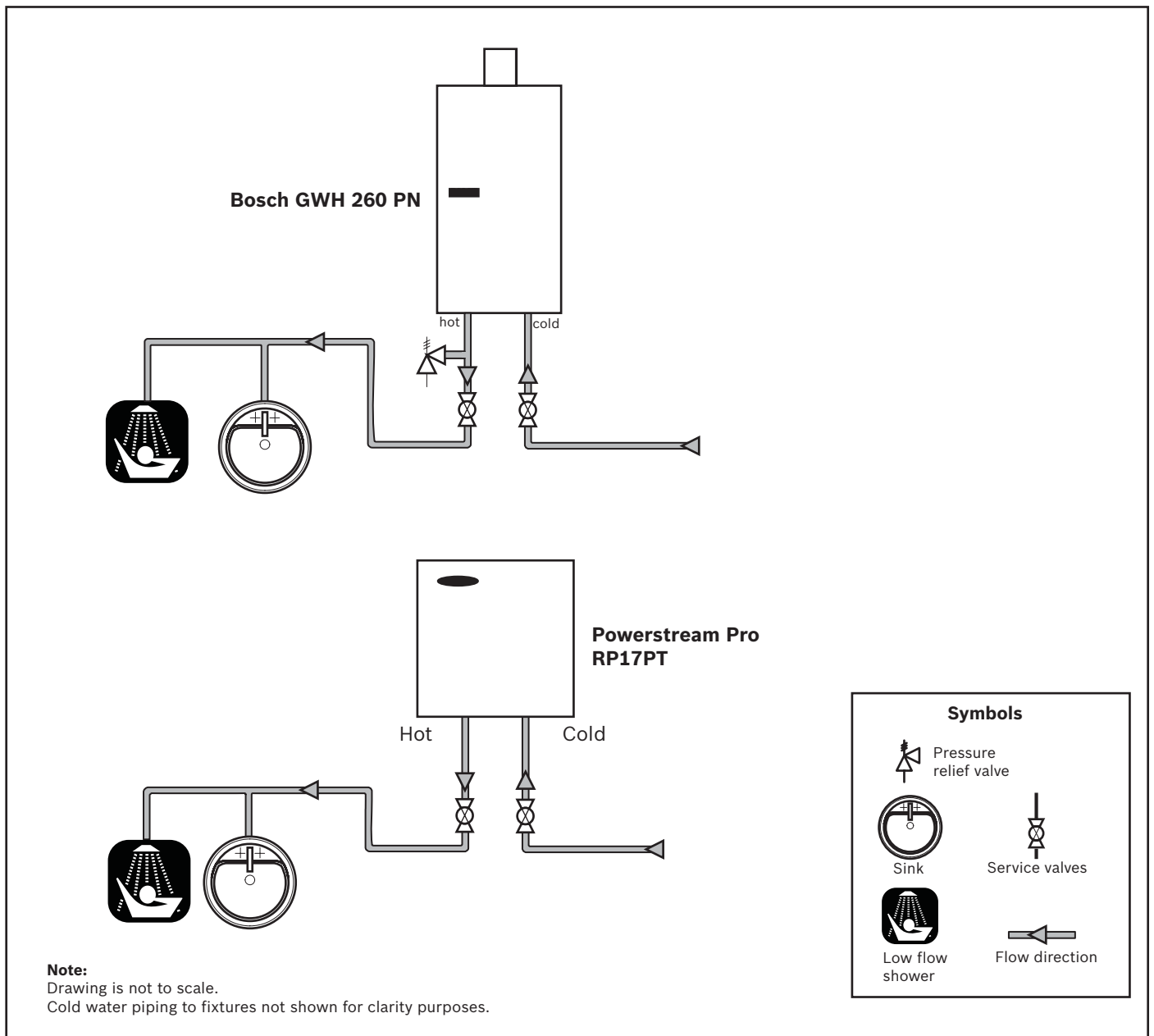

7.2.2 Powerstream Pro whole house applications

The RP27PT must be hard wired.

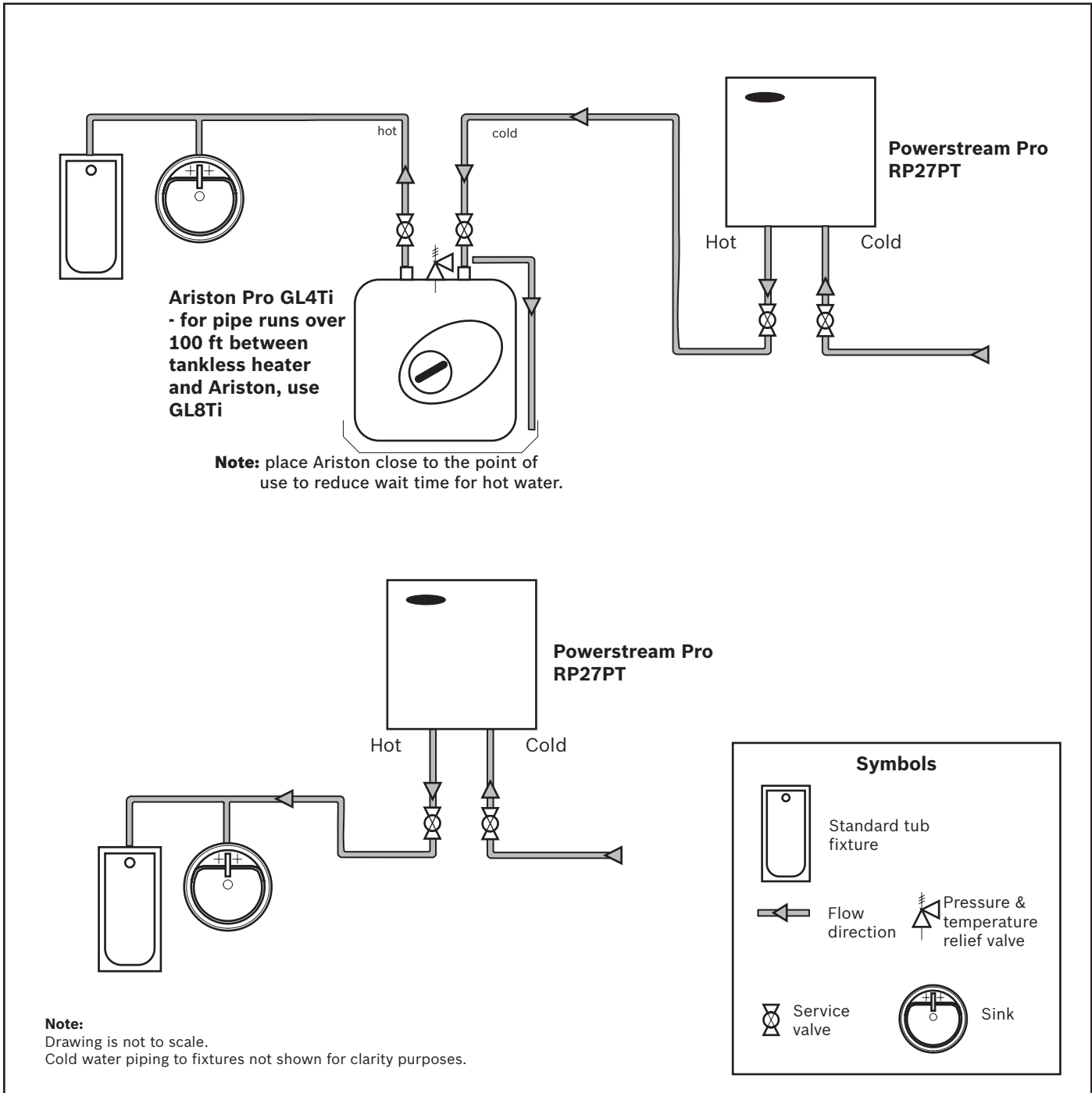

7.2.3 Powerstream Pro whole house application with domestic recirculation loop

The circulator should be controlled by an external aquastat, or with a timer to run only during times of expected hot water usage. Insulate piping in hot water recirculation loop to limit heat loss.



See Chapter 5.1 for recirculation pump parameters

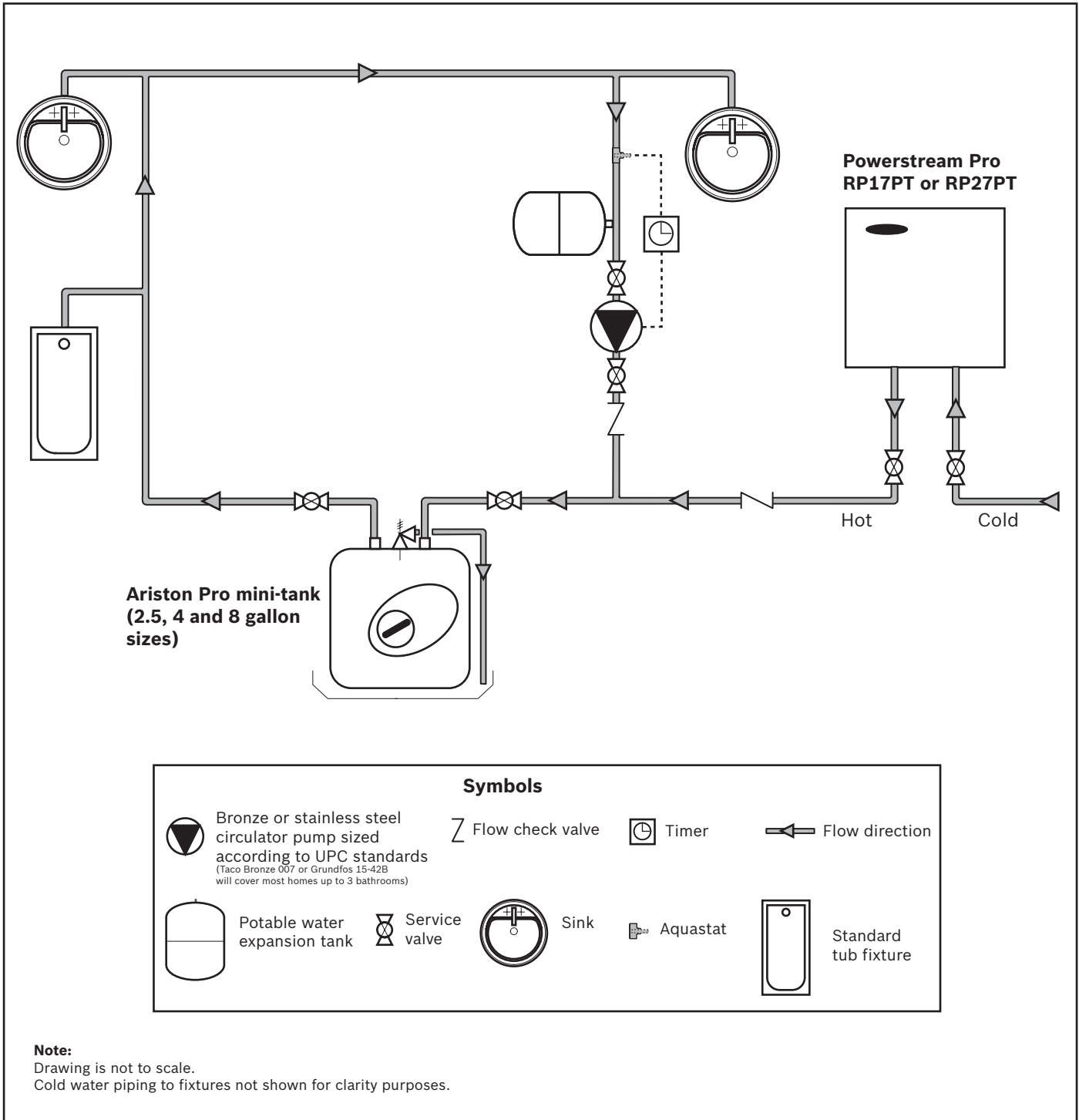

7.2.4 Bosch ProTankless gas water heater

Below are two examples of Bosch ProTankless gas water heater installations for the whole house. One example shows an Ariston mini tank in line for reduced hot water wait time and increased temperature stability.

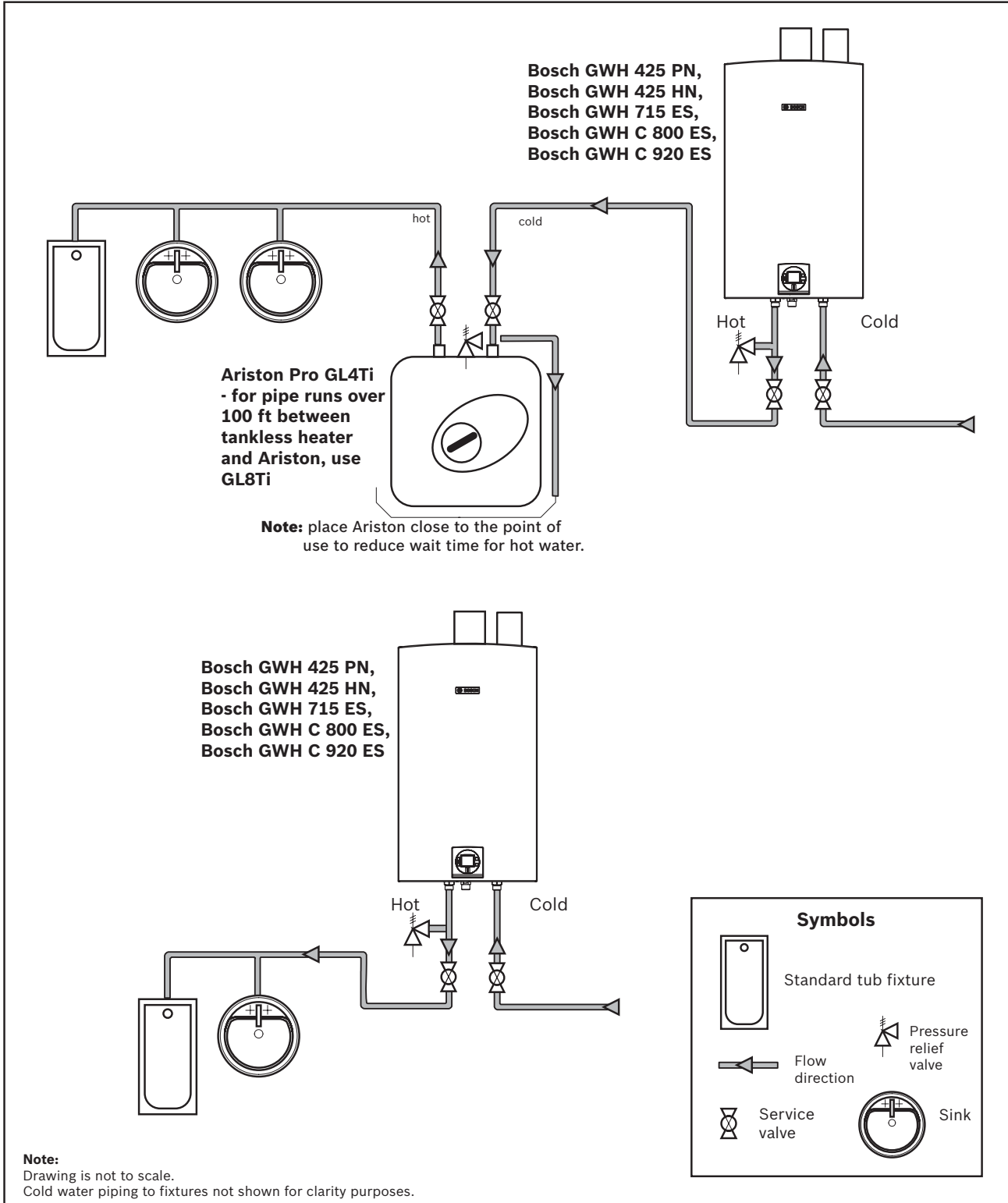

7.2.5 Bosch ProTankless gas water heater with domestic recirculation loop

The circulator should be controlled by an external aquastat or with a timer to run only during times of expected hot water usage. Insulate piping in hot water recirculation loop to limit heat loss.



See Chapter 5.1 for recirculation pump parameters

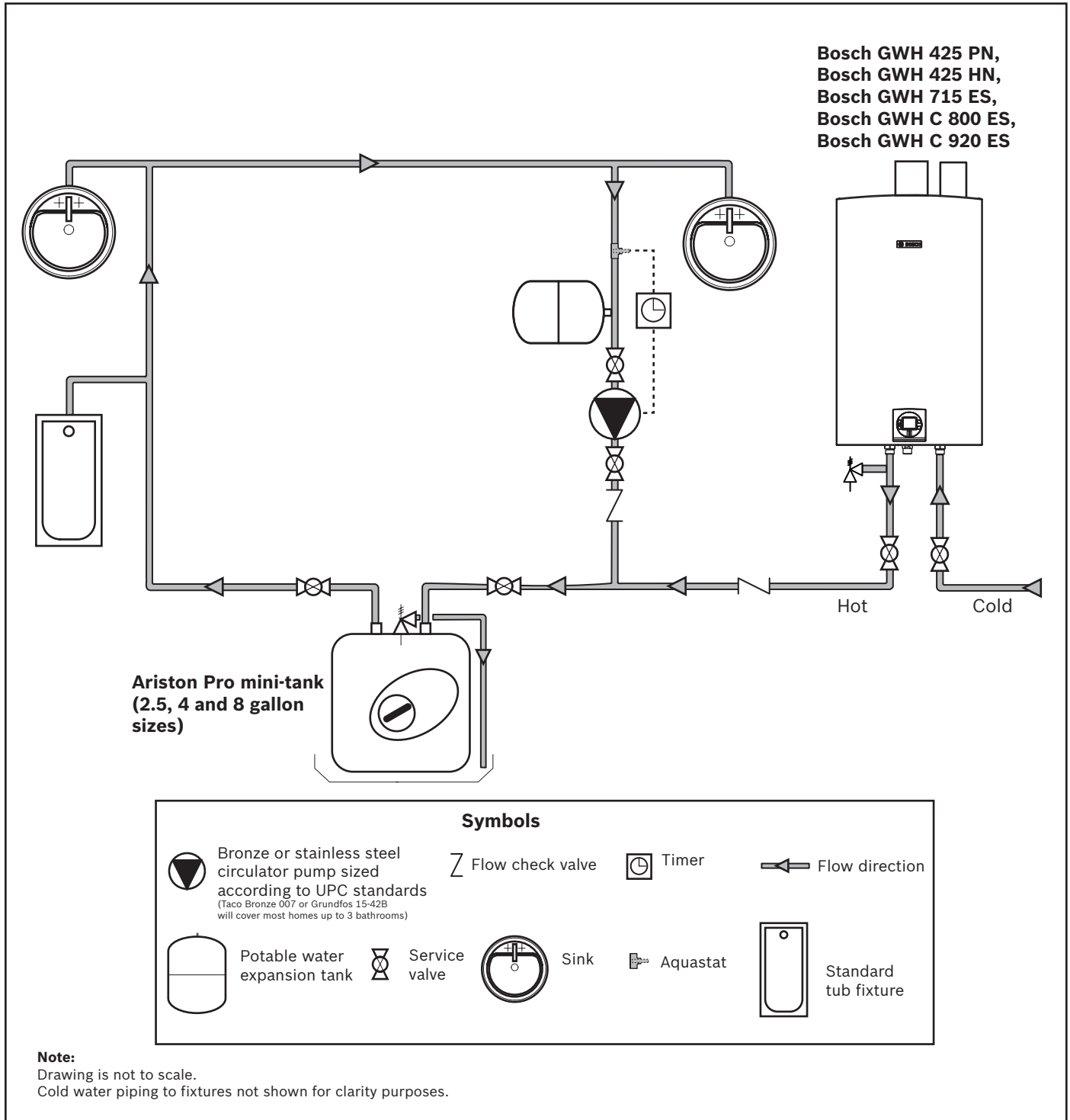

7.2.6 Bosch ProTankless gas water heater with direct recirculation loop

Use a circulator, aquastat and/or timer, to keep a loop of hot water constantly hot and ready to use. This limits wait time for hot water delivery to the tap and excessive waste of water. Insulate piping in hot water recirculation loop to limit heat loss.

i If the water heater is used within an approved hot water recirculation application and supplied with circulated water, the heat exchanger warranty is decreased. Please refer to the installation manual for detailed warranty period information.

i See Chapter 5.1 for recirculation pump parameters

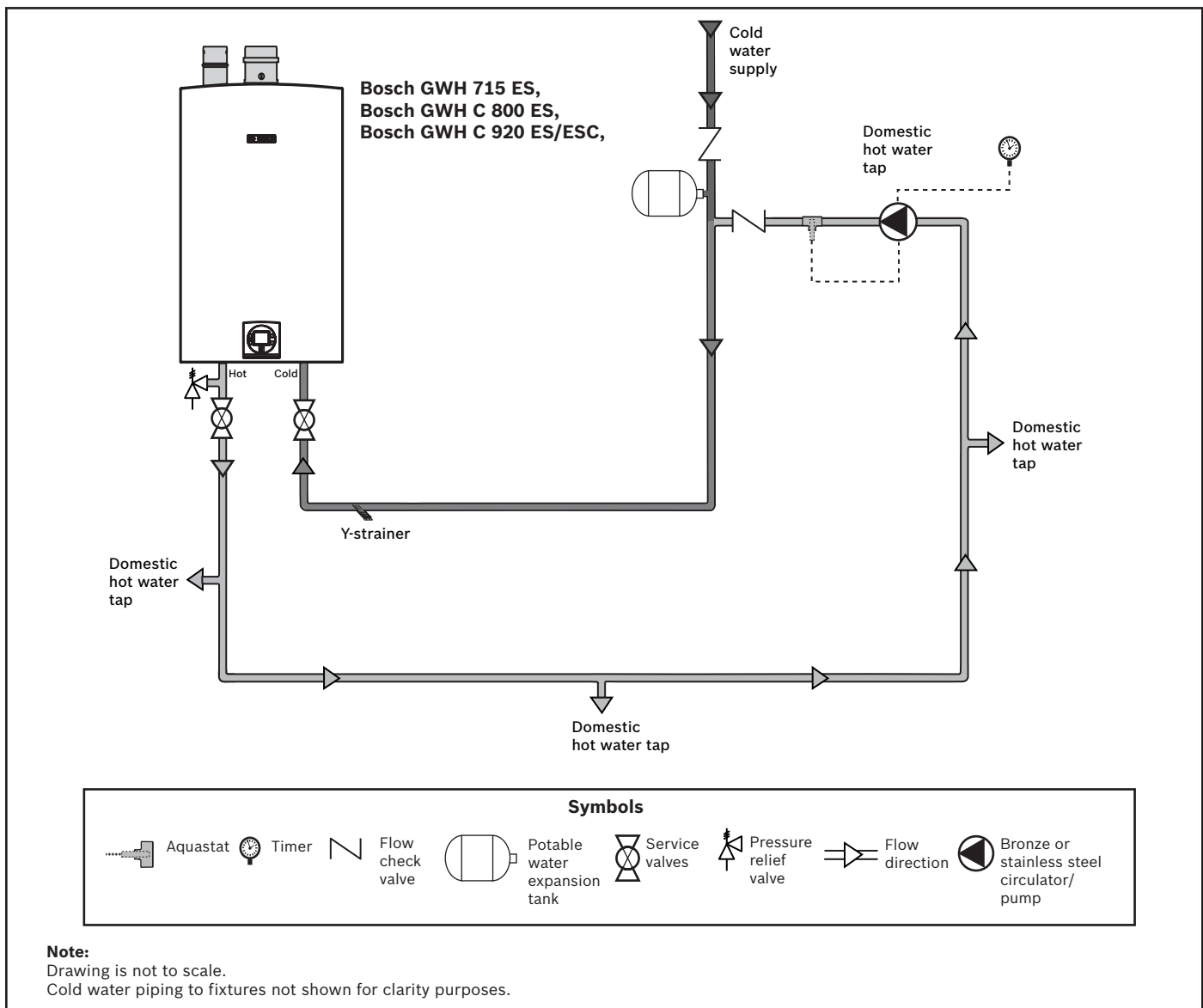

8 High Volume Potable Water Heating

Potable water

Potable water is water that is suitable for drinking. Bosch Water Heating appliances are approved to heat potable water only. Heating any other liquid other than potable water will void the manufacturer's warranty covering the appliance.

Introduction

This section lays out the options for high volume water heating for large residential and light commercial applications including continuous flows.

8.1 Cascading unit applications

A cascading application should be considered if the potential hot water demand exceeds the capacity of one GWH 715 ES, GWH C 800 ES, or GWH C 920 ES/ESC. The cascading set up supports variable flow inputs and is designed for large homes and commercial applications. Cascading, unlike parallel applications, maintains the activation flow rate of a single appliance.

8.1.1 GWH 715 ES, GWH C 800 ES, GWH C 920 ES/ESC cascading with domestic hot water recirculation

Cascading allows up to four appliances to be connected. One of the appliances will serve as the controlling Master appliance and will attempt to meet the hot water demand. If the hot water demand is beyond the capacity of the Master appliance, a signal is sent to one or more of the Slave appliances to begin operation.

System parameters:

- For applications with 200ft of pipe or more.
- The plumbing must be connected in the reverse return method with a minimum number of elbows to aid in balancing pressures between the appliances.
- Locate appliances close together for improved performance.
 - Maximum distance between appliances: 36"
 - Minimum distance between appliances: 1"
- Minimum pipe diameter: ¾" (2 appliances or less).
- Minimum pipe diameter: 1" (3 appliances or more).
- Minimum water pressure: 50 psi.
- Insulate pipes to prevent heat loss.

 See Chapter 5.1 for recirculation pump parameters

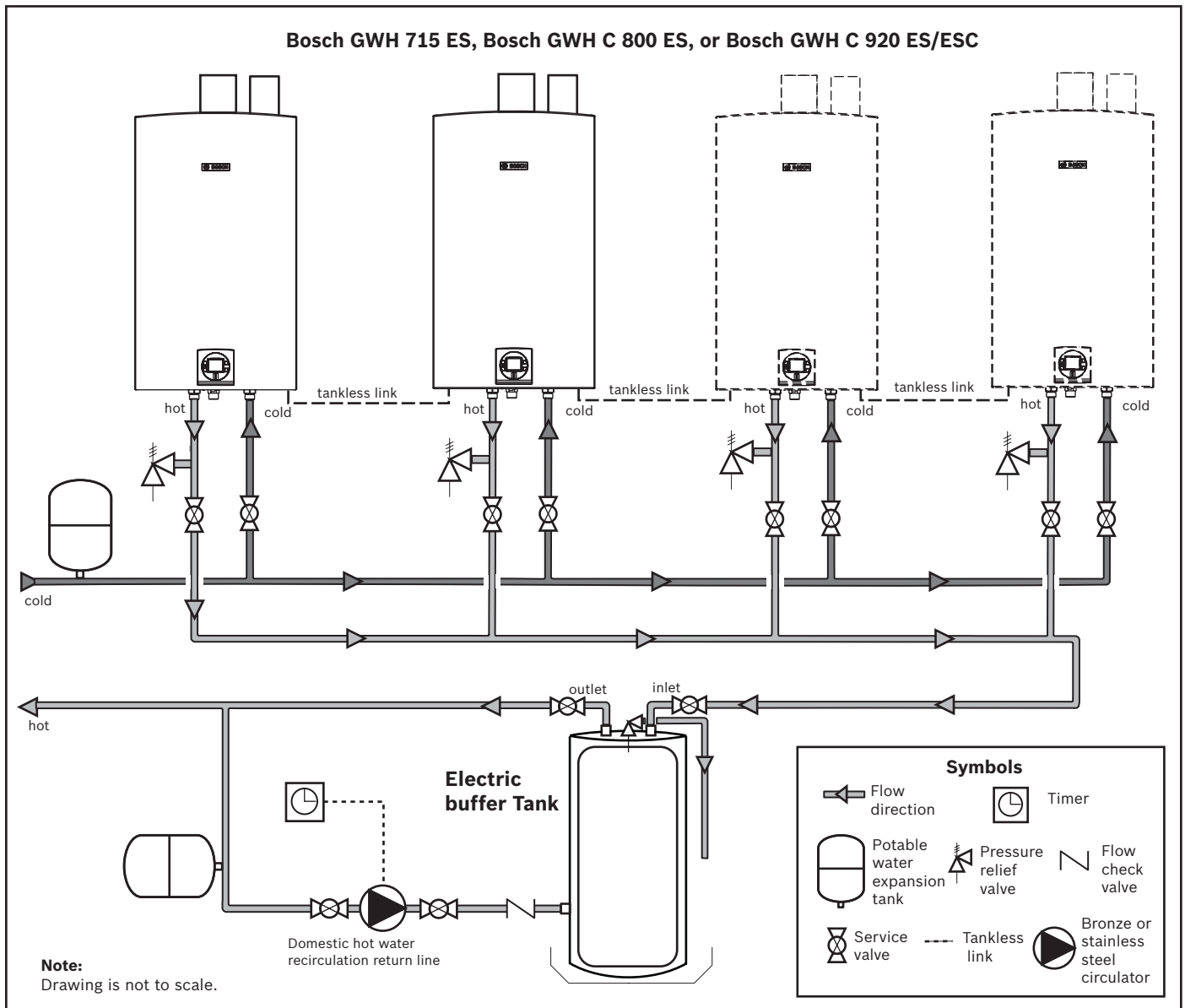

8.1.2 GWH 715 ES, GWH C 800 ES, GWH C 920 ES/ESC cascading with domestic hot water recirculation

System parameters:

- For applications with 200ft of pipe or less.



See Chapter 5.1 for recirculation pump parameters

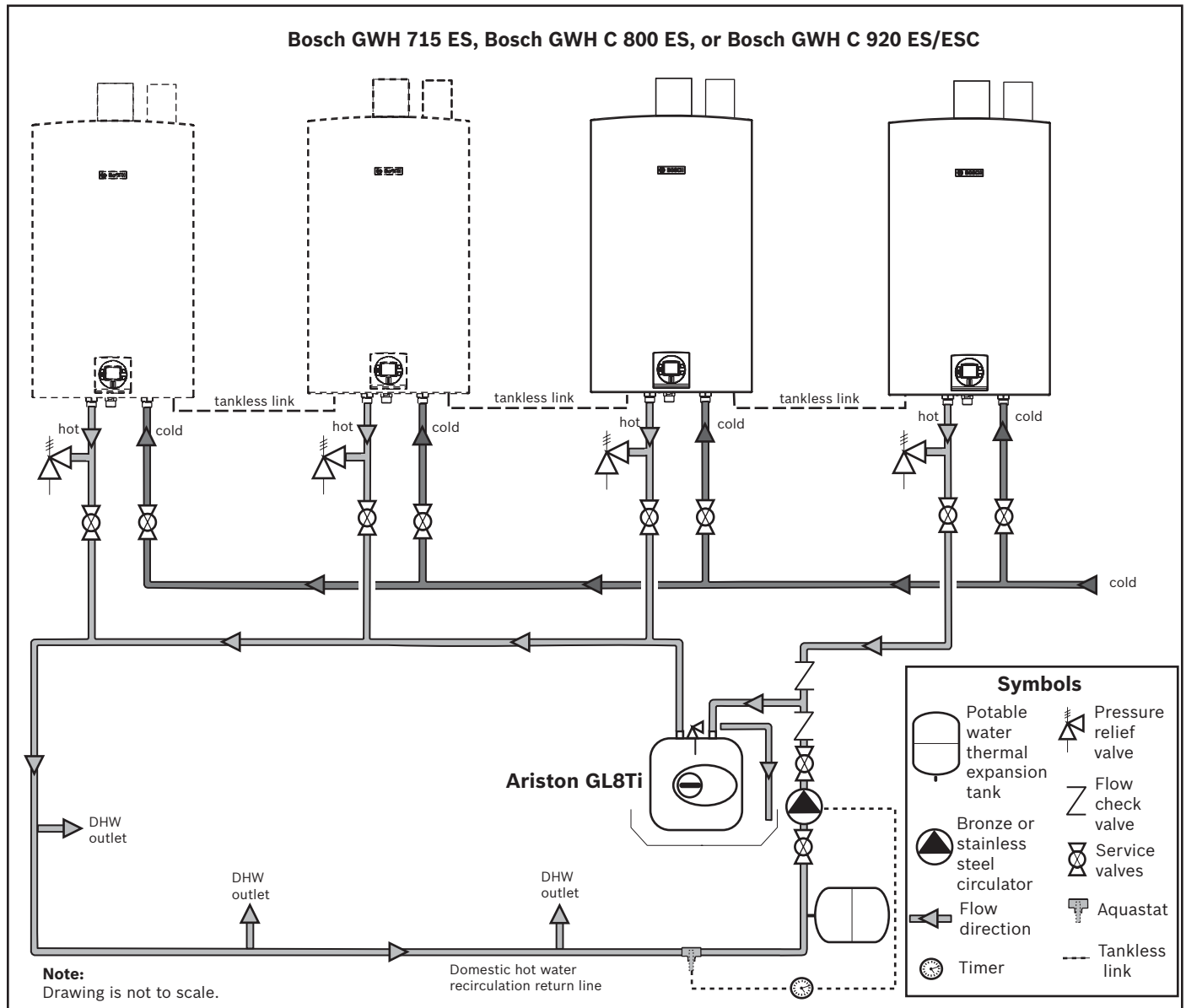

8.2 Parallel unit applications

Two Bosch ProTankless units will have double the activation rate of a single unit. The activation rate will continue to double with each additional unit added in parallel.

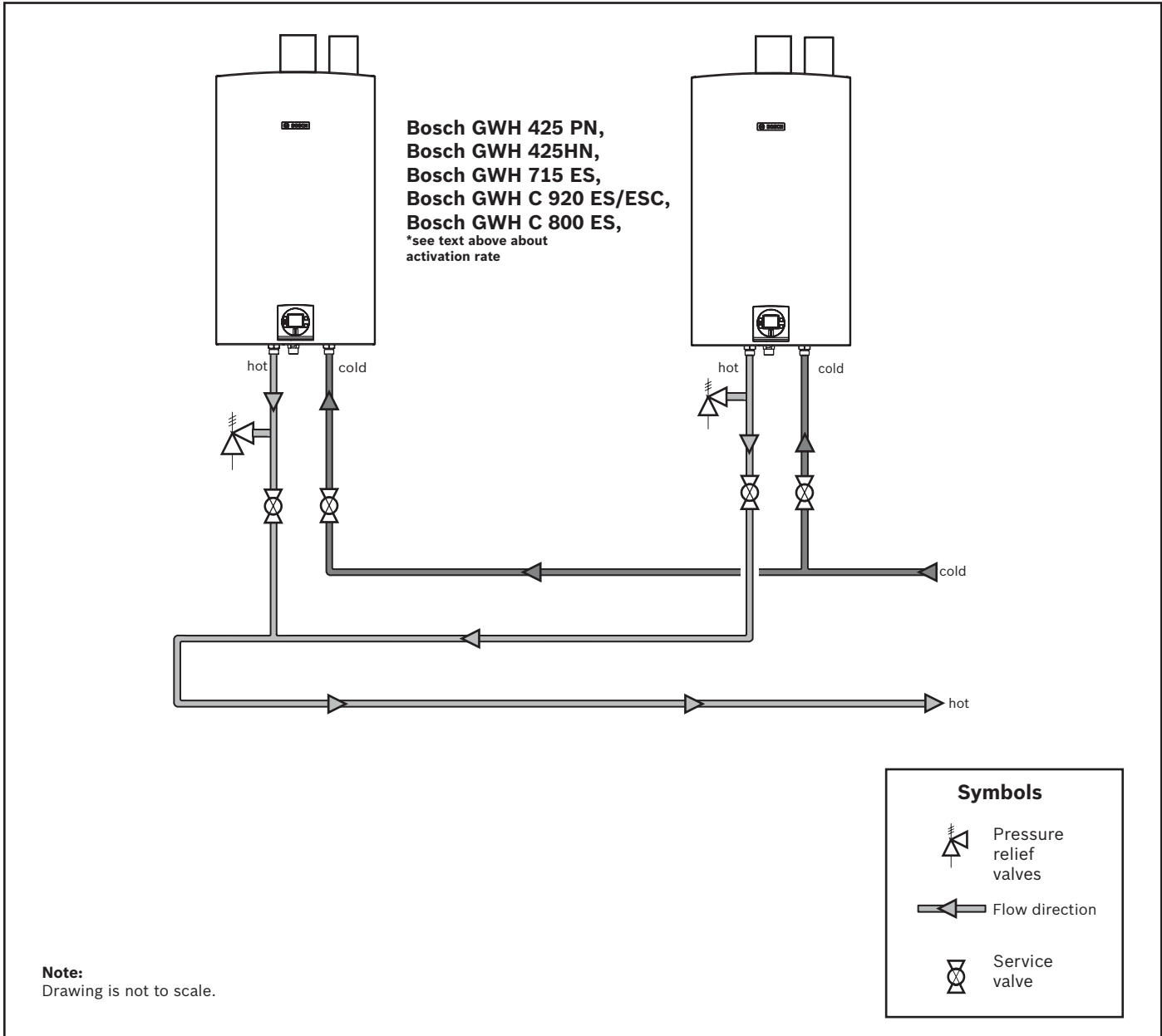

9 Residential Solar Applications

Introduction

This section gives a general overview of tank loading and in line booster applications for domestic hot water in conjunction with solar water heating. For additional system details, consult the Bosch Solar Technical Guide.

9.1 Tank loading

9.1.1 Solar DHW system with gas tankless water heater tank loading

In this system the gas tankless water heater keeps the comfort zone at top of tank at desired temperature.

- ▶ Use GWH 715 ES, GWH C 800 ES, or GWH C 920 ES with aquastat that activates circulator.
- ▶ Timer recommended to interrupt reheating during night time.

Aquastat / Water Heater setpoints		
Model Number	Aquastat setpoint	Water heater setpoint
GWH C 920 ESC	≤140°F	14°F above Aquastat setpoint
GWH C 920 ES	≤126°F*	140°F
GWH 715 ES	≤126°F*	140°F
GWH C 800 ES	≤126°F*	140°F

* If local codes require higher setpoint or to increase the recovery capacity of the water heater, contact Bosch Thermotechnology.



See Chapter 5.2 for tank loading pump parameters

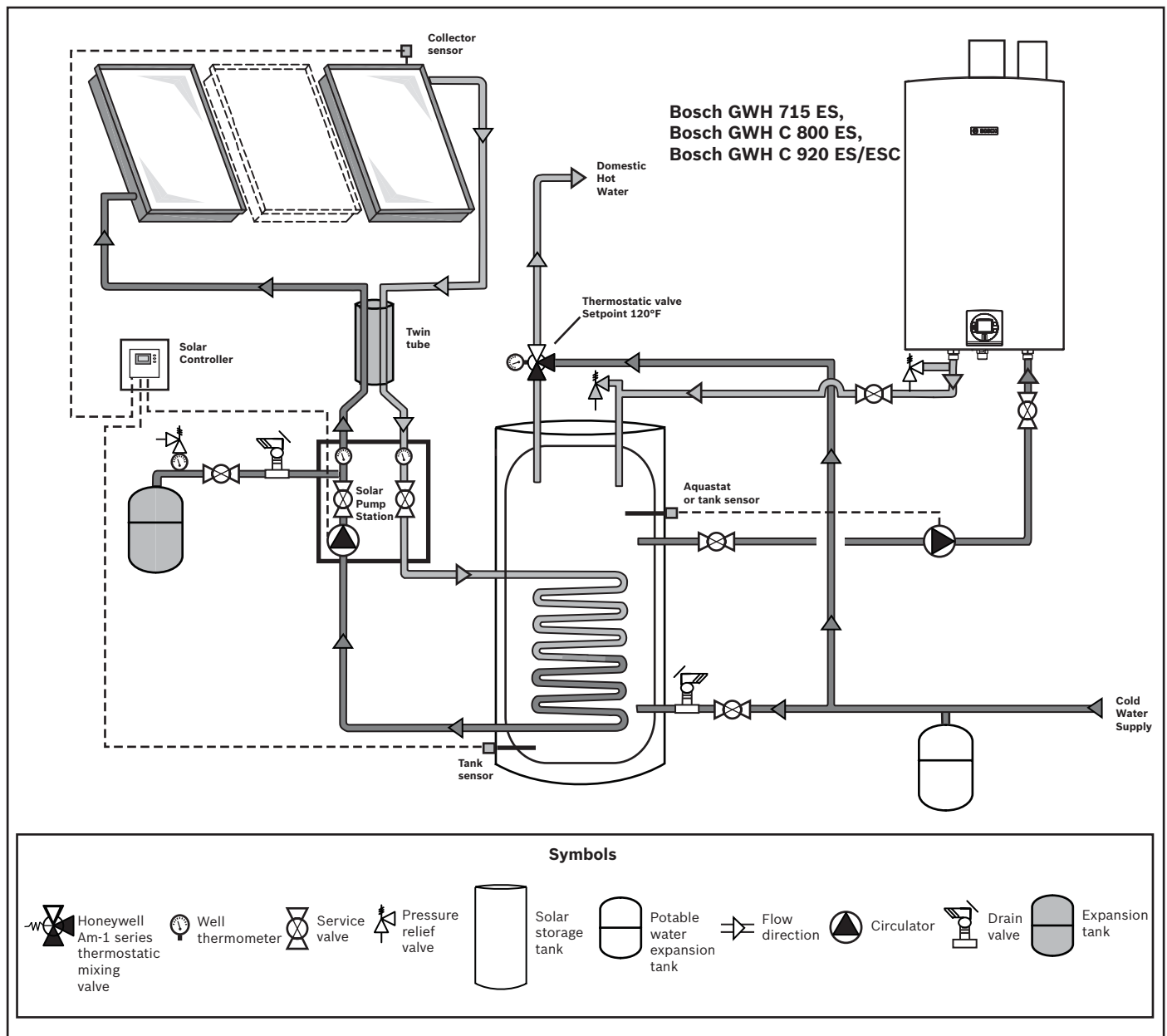

9.2 Booster applications

9.2.1 Solar DHW system with gas tankless water heater booster

The tankless water heater only runs when solar water needs a boost. The Ariston mini tank provides small amounts of DHW instantly and increases comfort by buffering DHW temperature. Recommended appliances: Bosch GWH 715 ES, GWH C 800 ES, GWH C 920 ES/ESC

- ▶ Thermostatic valve 1 ensures that warm solar water bypasses the water heater and directs cooler water through the appliance when reheating is needed.
- ▶ Thermostatic valve 2 acts as a tempering valve that brings potentially hot water temperatures down to a level that is safe for the inhabitants.

System parameters:

- ▶ Honeywell AM101 Thermostatic Valves required for proper operation;
- ▶ Remove check valves from Thermostatic Valve 1 as it is used as a diverter valve;
- ▶ Thermostatic Valve 2 is a tempering valve;
- ▶ Recommended setpoint 120°F for both Valves;
- ▶ Set tankless water heater temperature to 140° F
- ▶ Ariston mini tank will provide increased temperature stability and quicker hot water delivery. (recommended but not required)

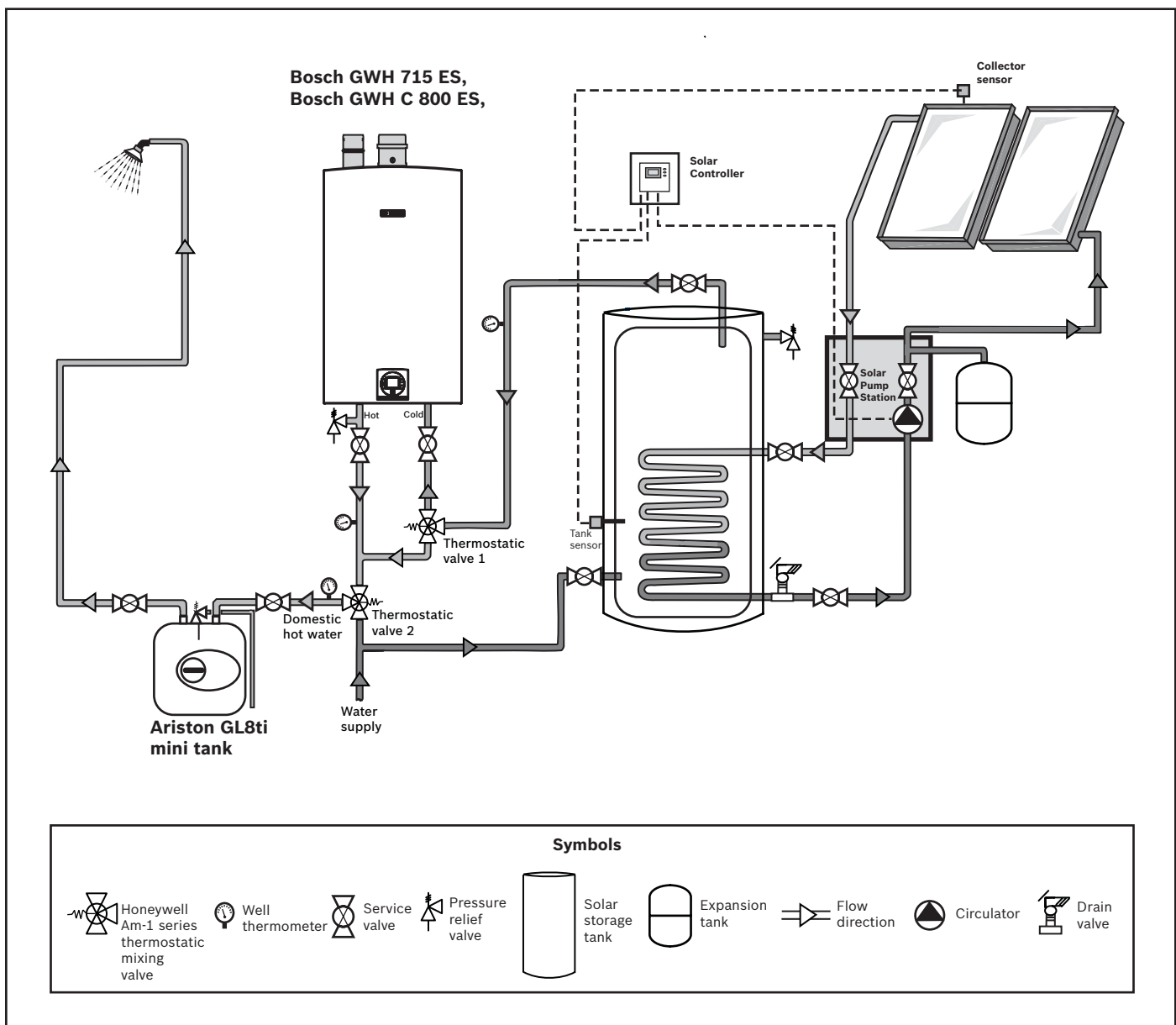

9.2.3 Solar DHW system with gas tankless water heater booster and recirculation loop

Similar to 4.3.2 with domestic hot water recirculation added. The tankless water heater only runs when solar heated water needs a boost. Buffer tank provides small amounts of DHW instantly and increases comfort by smoothing out DHW temperature. Recommended appliances: Bosch GWH 715 ES, GWH C 800 ES.

- ▶ Thermostatic valve 1 ensures that warm solar water bypasses the water heater and directs cooler water through the appliance when reheating is needed.
- ▶ Thermostatic valve 2 acts as a tempering valve that brings potentially hot water temperatures down to a level that is safe for the users.

System parameters:

- ▶ Honeywell AM101 Thermostatic Valves required for proper operation;
- ▶ Remove check valves from Thermostatic Valve 1 as it is used as a diverter valve;
- ▶ Thermostatic Valve 2 is a tempering valve;
- ▶ Recommended setpoint 120°F for both Valves;
- ▶ Set tankless water heater temperature to 140° F
- ▶ Ariston mini tank will provide increased temperature stability and quicker hot water delivery. (recommended but not required)
- ▶ Choose size of the Ariston mini tank to match the volume of the recirculation loop



See Chapter 5.1 for recirculation pump parameters

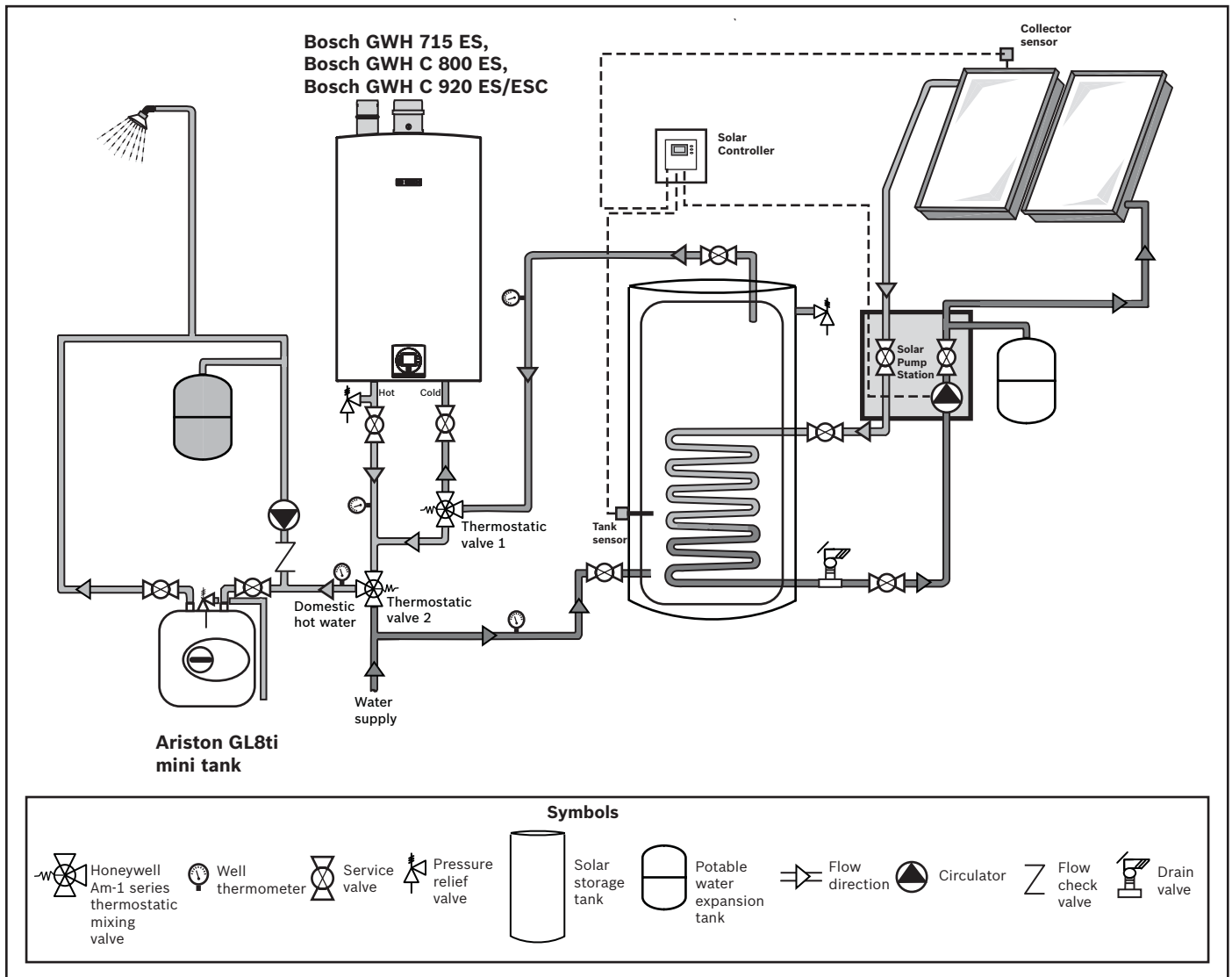

10 Commercial Solar Applications

Introduction

This section provides a general overview for commercial hot water systems in conjunction with solar water heating (e.g. schools, fitness centers). For additional system details, consult the Bosch Solar Technical Guide.

System parameters:

- ▶ Honeywell AM101 Thermostatic Valves required for proper operation.
- ▶ For optimal performance, the flow through the water heater should be between 3.5 -5 gpm



See Chapter 5.1 and 5.2 for recirculation pump parameters

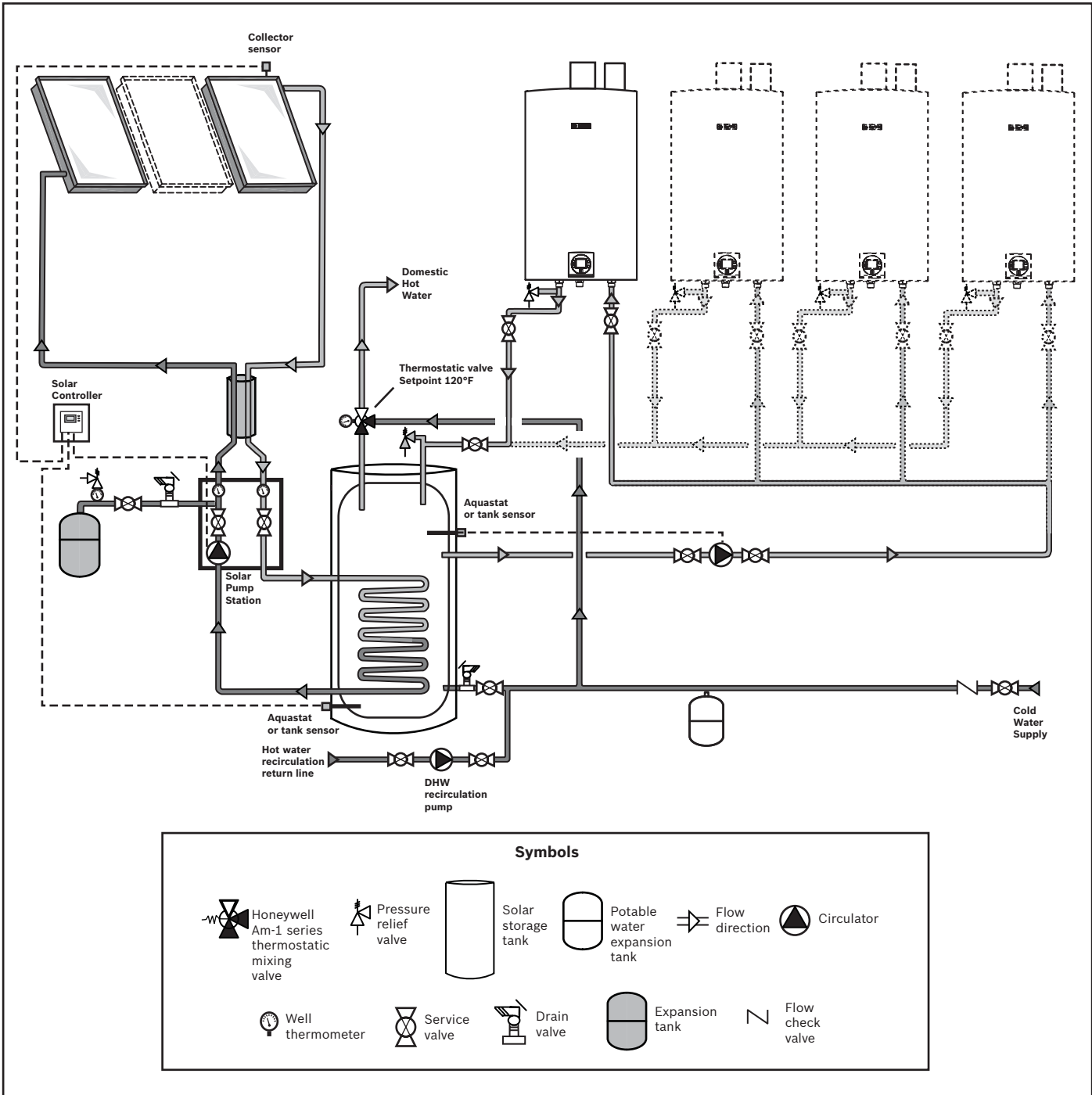

11 Commercial Water Heating Applications

Introduction

This section gives a general overview of high volume, high temperature water heating for commercial applications.

11.1 Commercial Kitchen applications

11.1.1 Commercial kitchen

This design allows for temperature stability with short, repeated hot water demands such as a super sprayer. It also provides high temperature water for a commercial dishwasher.

System parameters:

- ▶ Set Ariston mini-tank to maximum temperature.
- ▶ Set tankless water heater temperature per dishwasher temperature requirements.



When using the super sprayer, hot water draws must be longer than 15 seconds to avoid temperature fluctuations.

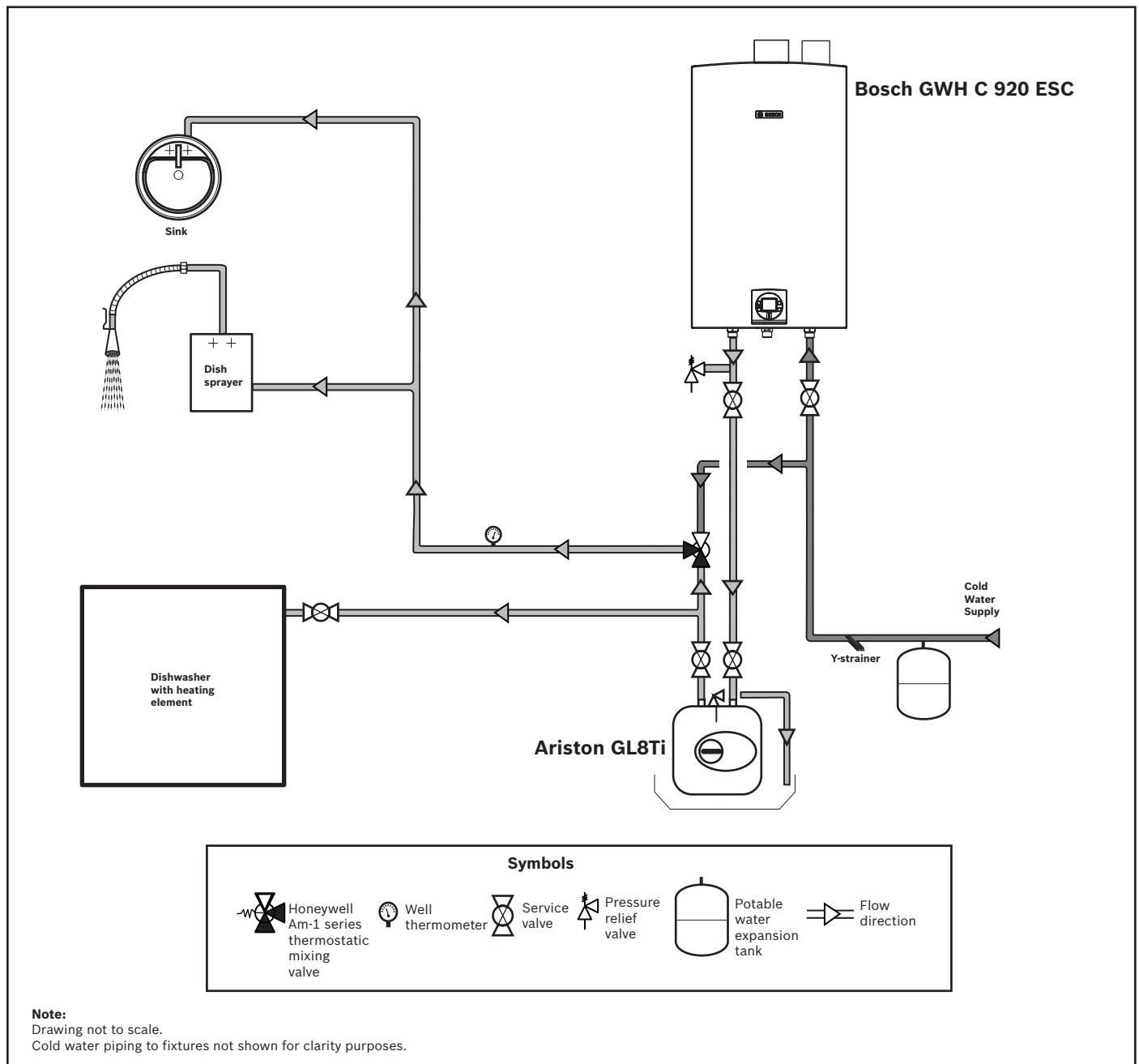

11.1.2 Commercial kitchen with domestic hot water recirculation







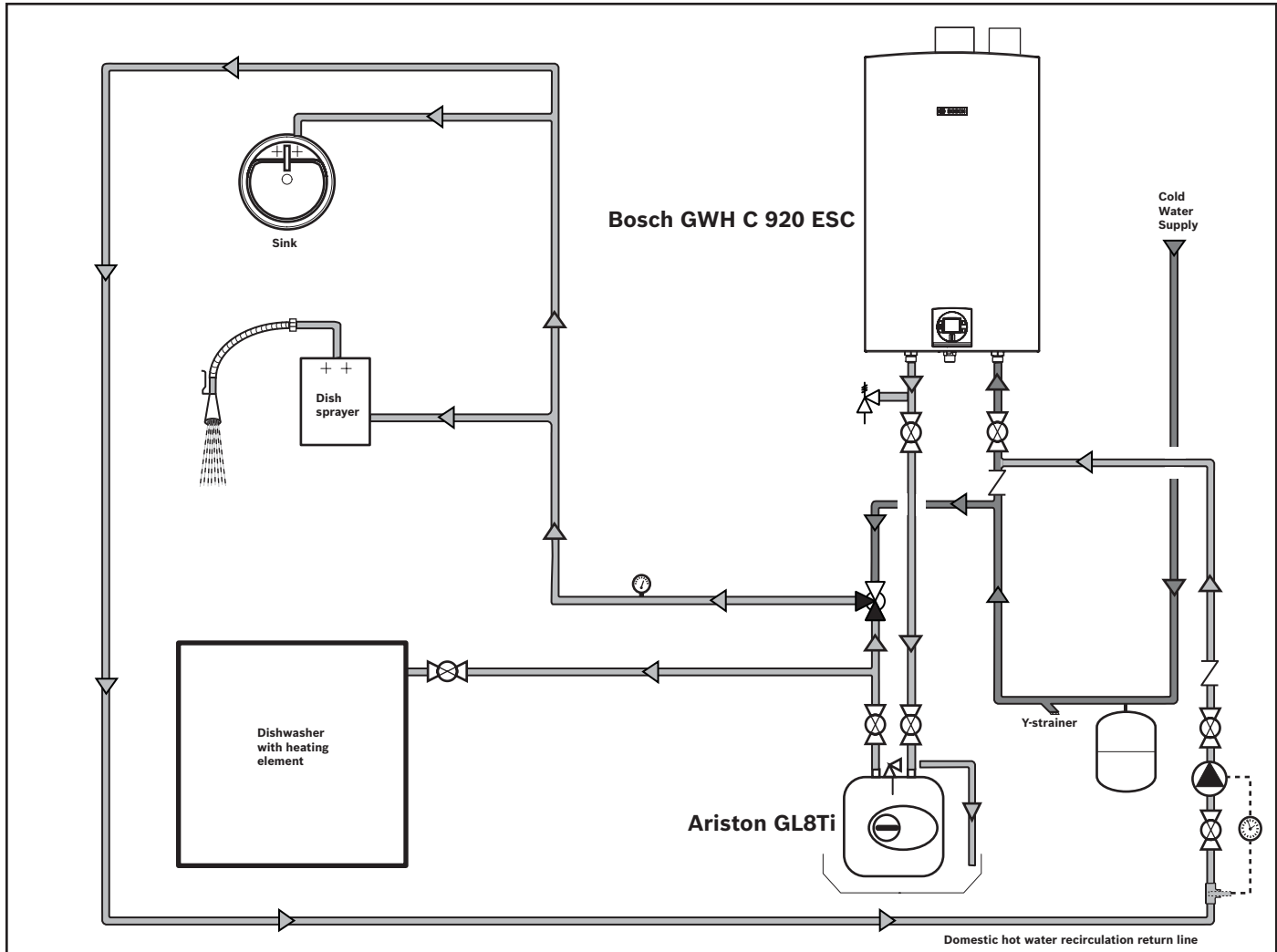



System parameters:

- ▶ For optimum performance in applications involving a commercial dishwasher, a hot water circulation loop is recommended.

i See Chapter 5.1 for recirculation pump parameters



Symbols

 Circulator (stainless steel or bronze)	 Honeywell Am-1 series thermostatic mixing valve	 Well thermometer	 Service valve	 Pressure relief valve	 Potable water expansion tank	 Flow direction	 Flow check valve	 Aquastat	 Timer
--	---	--	---	---	--	---	--	--	---

Note:
 Drawing not to scale.
 Cold water piping to fixtures not shown for clarity purposes.

11.2 Basic tank loading with domestic recirculation

The following application outlines general tank loading with one or more gas tankless water heaters in parallel. Domestic hot water recirculation shown is optional.

System parameters:

- Aquastat/tank sensor Tset 120-140°F, <10°F differential.
- 30-119 gallon storage tank recommended
- DHW return line can tie directly into tank if fittings are available.
- Individual pumps (i.e. UP26-99) can be used on supply to each heater or one pump (as shown) for the entire system

Aquastat / Water Heater setpoints		
Model Number	Aquastat setpoint	Water heater setpoint
GWH C 920 ESC	≤140°F	14°F above Aquastat setpoint
GWH C 920 ES	≤126°F*	140°F
GWH 715 ES	≤126°F*	140°F
GWH C 800 ES	≤126°F*	140°F

* If local codes require higher setpoint or to increase the recovery capacity of the water heater, contact Bosch Thermotechnology.

i See Chapter 5.1 and 5.2 for pump parameters

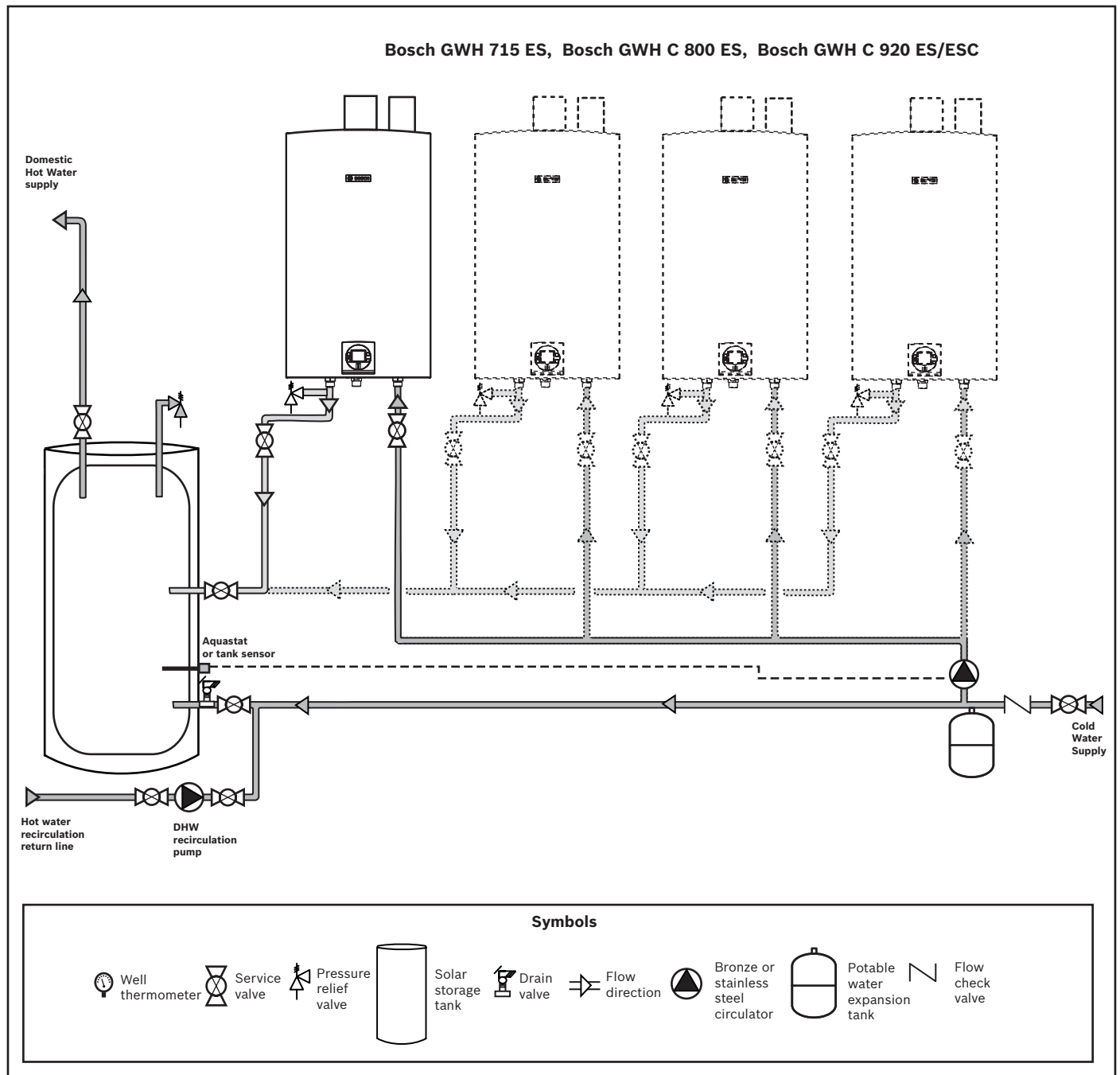

11.3 Advanced tank loading commercial hot water system

The following application outlines an advanced tank loading application for commercial hot water systems (e.g. hotels, fitness centers). This design allows for complete isolation of the system for maintenance reasons and gives the ability to bypass certain system components in case of failure. A second hot water storage tank is shown for additional hot water supply and back up in case of tank failure.

System parameters:

 See Chapter 5.1 and 5.2 for pump parameters

Aquistat / Water Heater setpoints		
Model Number	Aquistat setpoint	Water heater setpoint
GWH C 920 ESC	≤140°F	14°F above Aquistat setpoint
GWH C 920 ES	≤126°F*	140°F
GWH 715 ES	≤126°F*	140°F
GWH C 800 ES	≤126°F*	140°F

* If local codes require higher setpoint or to increase the recovery capacity of the water heater, contact Bosch Thermotechnology.

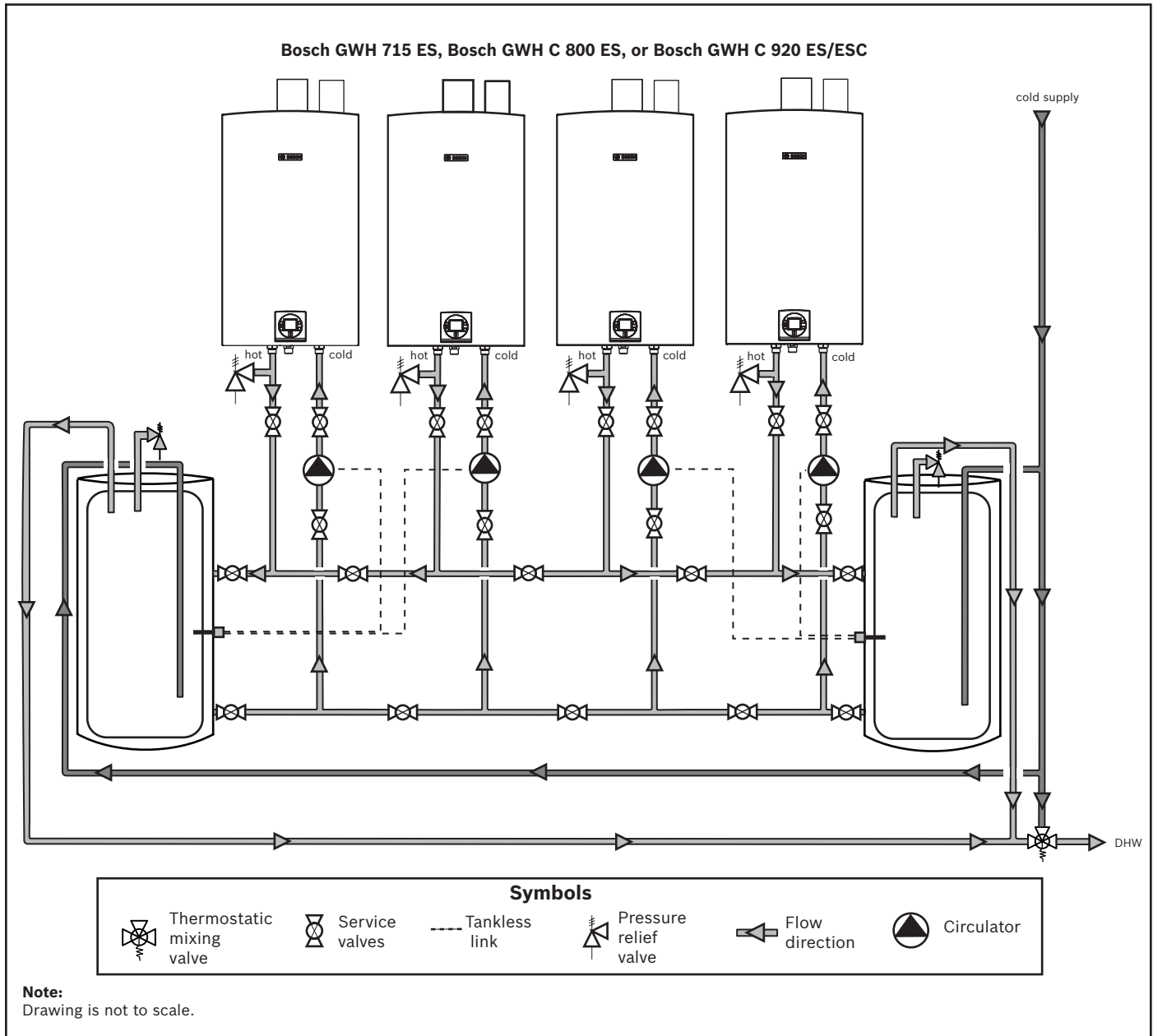



BOSCH

Bosch Thermotechnology Corp.
50 Wentworth Avenue
Londonderry, NH 03053

Tel: 1-866-642-3198
Fax: 1-603-584-1681
www.boschpro.com